

ASTRONOMY

Problem of The Day

compiled and edited by FAHIM RAJIT HOSSAIN
farahoshwadhin.13@gmail.com



Note. I would like to express my heartfelt gratitude to #Bombom, who initiated this work—all problem-making credit goes to him. My role is merely to convert it into a \LaTeX document for enhanced readability while providing detail/alternative solutions where possible, along with some insightful remarks.

Most *Day* problems are relatively easy and can be solved with national-level preparation, making them suitable for IOAA Junior. However, every *PoTW* problem is at the IOAA level, typically ranging between ***T6*** – ***T10***.

The original work can be found here: <https://www.instagram.com/astro.potd/>

Contents

1 Week 1	5	6 Week 6	10	Day 74: 3rd IOAA, Iran	
Day 1	5	Day 36	10	2009	15
Day 2	5	Day 37	10	Day 75	15
Day 3	5	Day 38	10	Day 76	15
Day 4	5	Day 39	10	Day 77: PoTW 11	15
Day 5	5	Day 40	10		
Day 6	5	Day 41	10	12 Week 12	16
Day 7: Problem of The		Day 42: PoTW 6	10	Day 78	16
Week 1	5			Day 79	16
		7 Week 7	11	Day 80	16
2 Week 2	6	Day 43	11	Day 81	16
Day 8	6	Day 44	11	Day 82	16
Day 9	6	Day 45	11	Day 83	16
Day 10	6	Day 46	11		
Day 11	6	Day 47	11	13 Solutions	17
Day 12	6	Day 48: APAO 15	11	Solution of Day 1	17
Day 13	6	Day 49: PoTW 7	11	Solution of Day 2	17
Day 14: PoTW 2	6			Solution of Day 3	17
		8 Week 8	12	Solution of Day 4	18
3 Week 3	7	Day 50	12	Solution of Day 5	19
Day 15	7	Day 51	12	Solution of Day 6	19
Day 16	7	Day 52	12	Solution of Day 7	20
Day 17	7	Day 53	12	Solution of Day 8	22
Day 18	7	Day 54	12	Solution of Day 9	22
Day 19	7	Day 55	12	Solution of Day 10	23
Day 20	7	Day 56: PoTW 8	13	Solution of Day 11	23
Day 21: PoTW 3	7			Solution of Day 12	24
		9 Week 9	13	Solution of Day 13	24
4 Week 4	8	Day 57	13	Solution of Day 14	24
Day 22	8	Day 58	13	Solution of Day 15	26
Day 23	8	Day 59	13	Solution of Day 16	26
Day 24	8	Day 60	13	Solution of Day 17	27
Day 25	8	Day 61	13	Solution of Day 18	27
Day 26	8	Day 62	13	Solution of Day 19	28
Day 27	8	Day 63: PoTW 9	13	Solution of Day 20	28
Day 28: PoTW 4	8			Solution of Day 21	29
		10 Week 10	14	Solution of Day 22	32
5 Week 5	9	Day 64	14	Solution of Day 23	32
Day 29	9	Day 65	14	Solution of Day 24	33
Day 30	9	Day 66	14	Solution of Day 25	33
Day 31	9	Day 67	14	Solution of Day 26	34
Day 32	9	Day 68	14	Solution of Day 27	34
Day 33	9	Day 69	14	Solution of Day 28	35
Day 34	9	Day 70: PoTW 10	14	Solution of Day 29	36
Day 35: PoTW 5	9			Solution of Day 30	37
		11 Week 11	15	Solution of Day 31	37
		Day 71	15	Solution of Day 32	38
		Day 72	15	Solution of Day 33	38
		Day 73	15	Solution of Day 34	39
				Solution of Day 35	40

Solution of Day 36	41	Solution of Day 52	50	Solution of Day 68	59
Solution of Day 37	42	Solution of Day 53	50	Solution of Day 69	60
Solution of Day 38	42	Solution of Day 54	51	Solution of Day 70	60
Solution of Day 39	43	Solution of Day 55	51	Solution of Day 71	61
Solution of Day 40	43	Solution of Day 56	51	Solution of Day 72	61
Solution of Day 41	43	Solution of Day 57	52	Solution of Day 73	62
Solution of Day 42	44	Solution of Day 58	53	Solution of Day 74	63
Solution of Day 43	45	Solution of Day 59	53	Solution of Day 75	63
Solution of Day 44	45	Solution of Day 60	54	Solution of Day 76	63
Solution of Day 45	46	Solution of Day 61	54	Solution of Day 78	64
Solution of Day 46	46	Solution of Day 62	55	Solution of Day 79	64
Solution of Day 47	47	Solution of Day 63	55	Solution of Day 80	64
Solution of Day 48	47	Solution of Day 64	57	Solution of Day 81	65
Solution of Day 49	48	Solution of Day 65	58	Solution of Day 82	65
Solution of Day 50	49	Solution of Day 66	59		
Solution of Day 51	49	Solution of Day 67	59		

Topic Wise Contents

Topic	Problems	Topic	Problems
Physics	Day 61	Astrometry	Day 2
	Day 73	Celestial Mechanics	Day 1
	Day 76		Day 11
Astronomical Phenomenon	Day 16		Day 21
Astronomical Geometry Solar System	Day 17		Day 22
	Day 25		Day 28
	Day 31		Day 35
	Day 41		Day 37
	Day 47		Day 40
	Day 49		Day 62
	Day 53		Day 63
	Day 58		Day 68
Photometry & Radiation	Day 3		Day 74
	Day 4		Day 77
	Day 13		Day 82
	Day 22	Astrology	Day 50
	Day 23	Binary Stars	Day 39
	Day 28		Day 72
	Day 43		Day 78
	Day 69	Observation	Day 9
Day 70	Stellar Physics	Day 8	
Day 6		Day 15	
Day 7		Day 19	
Day 14		Day 38	
Day 18		Day 57	
Day 24		Day 66	
Day 27		Day 71	
Day 28		Day 81	
Celestial Coordinate Spherical Astronomy & Time	Day 34	Spectroscopy	Day 26
	Day 46		Day 45
	Day 52		Day 51
	Day 54		Day 48
	Day 64	Galactic Astrophysics	Day 10
	Day 65		Day 29
	Day 67		Day 32
	Day 79		Day 48
	Day 80	Cosmology	Day 4
	Day 83		Day 20
	Day 12		Day 36
	Day 30		Day 44
Optics and Instruments	Day 33		Day 56
	Day 55		
	Day 59		
	Day 60		

1 Week 1

Day 1

It is known that a spacecraft is orbiting its parent star. The orbit of this spacecraft has a semi-major axis (a) of 0.8 AU, and a semi-minor axis (b) of 0.6 AU. It is also known that the mass of the parent star is $2 M_{\odot}$. Determine the velocity of the spacecraft at its' periastron. [\[Solution\]](#)

Day 2

James is an astronomer trying to measure the distance of a star to our very own star, The Sun. He measured the angle of parallax to be $0.03''$. Use the information above to determine this star's distance to The Sun! [\[Solution\]](#)

Day 3

Sirius **A** is an A-type star located 8.6 lightyears away. It is known to have a radius of $1.71 R_{\odot}$. The Sun has a magnitude of -26.8 , the Solar Constant (S_{\odot}) is 1370 W/m^2 , and the Solar Radius (R_{\odot}) is 6.96×10^8 meters. Given that Sirius **A**'s magnitude is -1.61 , determine its' effective temperature in terms of solar effective temperature. [\[Solution\]](#)

Day 4

Suppose we are living in a flat universe with $H_0 = 70$ km/s/Mpc, $T_0 = 2.73 \text{ K}$, and composed of matter ($\Omega_{m,0} = 0.25$), radiation ($\Omega_{r,0} = 8.4 \times 10^{-5}$), and dark energy. Calculate the Hubble Parameter (H) at the time of recombination era, given that Hydrogen recombination occurs at $T = 3000 \text{ K}$. [\[Solution\]](#)

Day 5

An observer on Earth observes a star and finds that the peak of the spectrum is at 410 nm, and the Hydrogen- α line is at 842 nm. Bombom lives on a planet orbiting that star. Calculate the surface brightness of that star as seen by Bombom. [\[Solution\]](#)

Day 6

Jack is a 15-year-old who is very interested in Astronomy, so he tries to study where the stars will rise and where the stars will set. In doing so, he chose his favorite star, Rigel (β Ori). He knows that Rigel has an equatorial coordinate of $(05^h 14^m 32.3^s, -08^{\circ} 12' 05.9'')$. Given that Jack lives in Melbourne ($37^{\circ} 50' 27.3660'' \text{ S}$, $144^{\circ} 56' 47.2452'' \text{ E}$), and the date is currently 10th of April, Determine the civil time and Azimuth of Rigel when it rises. [\[Solution\]](#)

Day 7: Problem of The Week 1

The Great Square of Pegasus is an Asterism that consists of four stars

$$\alpha \text{ Peg: } 23^h 05^m, 15^{\circ} 18'$$

$$\beta \text{ Peg: } 23^h 04^m, 28^{\circ} 11'$$

$$\gamma \text{ Peg: } 0^h 14^m, 15^{\circ} 17'$$

$$\delta \text{ Peg: } 23^h 09^m, 29^{\circ} 11'$$

Find the coordinates for the intersection of the two diagonals. [\[Solution\]](#)

2 Week 2

Day 8

Star **A** has a mass of $3 M_{\odot}$ and a radius of $2 R_{\odot}$. Assuming the density of Star **A** is homogenous. Determine the pressure in the core of Star **A**.

[Solution]

Day 9

Name the Constellations!

[Solution]



Day 10

The Galactic longitude of a star is $l = 34^\circ$. Its radial velocity concerning the Sun is $v_r = 76$ km/s. Assuming that the stars in the disk of the Galaxy are orbiting around the galactic center in circular orbits, the Sun is 8 kpc from the center of the Galaxy. It has a constant velocity of $v_0 = 250$ km/s. Calculate the distance of the star from the center of the Galaxy.

[Solution]

Day 11

Consider a smooth runway along the moon's equator. A rocket ship began to move in an attempt to take off along the runway. Even though there is no atmosphere on the moon to lift the plane's wings, at some point the plane starts to lift off the runway. What was the velocity of the craft at that time (relative to the Moon's ground surface)?

[Solution]

Day 12

The Galactic Center is believed to contain a supermassive black hole with a mass $M = 4 \times 10^6 M_{\odot}$. The astronomy community is trying to resolve its event horizon, which is a challenging task. For a non-rotating black hole, this is the Schwarzschild radius. Assume that we have an Earth-sized telescope (using Very Long Baseline Interferometry). What wavelengths should we adopt in order to resolve the event horizon of the black hole?

[Solution]

Day 13

The apparent magnitude of the galaxy is 9, and the absolute magnitude is -25 mag. If there is an absorption of 0.15 mag/kpc. Determine the distance to the galaxy.

[Solution]

Day 14: PoTW 2

Alice is looking at the sky. To her west, there is an infinitely long wall, 5 meters in height and 3 meters away from Alice, going from north to south. Alice observes that star **number 1** reaches the top of the wall at an azimuthal angle of $A = 20^\circ$ W and also observes **star 2** reach the top of the wall at an azimuthal angle of $A = 60^\circ$ W, both at the same time.

Now, consider all cities on Earth that observe **stars 1** and **2** with the same altitude. Out of all of these cities, how far away is the city closest to Alice?

[Solution]

3 Week 3

Day 15

The solar wind hits the Earth with a velocity of 400 km/s and a proton density of around 7 cm^{-3} .

The mass loss rate of the Sun due to the solar wind is... [\[Solution\]](#)

Day 16

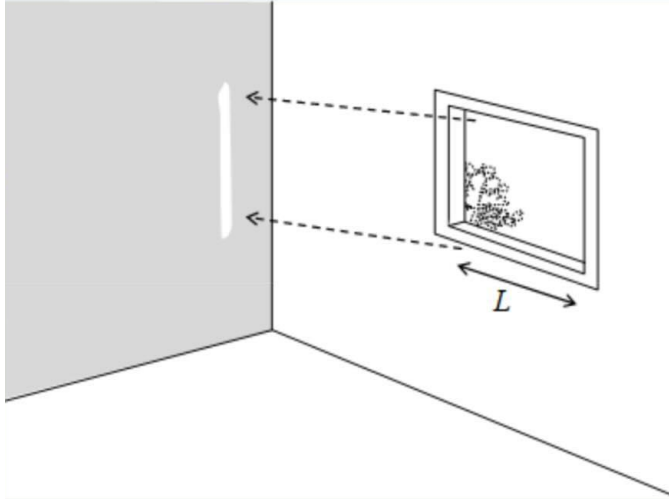

An astronomer who lives in a city on the equator is building a house. They want to have a particular corner of a room that receives direct sunlight through a window when the sun is rising on the (northern) summer solstice day. The house will have a rectangular shape oriented such that the front side is facing 16 degrees to the north from true east, which makes this house look odd compared to neighboring houses. The thickness of the wall is 15 cm. What is L , the width of the window? [\[Solution\]](#)

Day 17

A neutron star has a jet width of 5° , and the jet's poles are 20° off of its rotational axis. Determine the probability that this pulsar is detected from Earth. [\[Solution\]](#)

Day 18

During Winter Solstice, Venus seems to have reached the greatest eastern elongation. If given that Venus is on the ecliptic plane, determine the equatorial coordinates of Venus. [\[Solution\]](#)

Day 19

A main sequence star with the radius and mass of $R = 4 R_\odot$, $M = 6 M_\odot$ has an average magnetic field of $1 \times 10^{-4} \text{ T}$. Calculate the strength of the magnetic field of the star when it evolves to a neutron star with the radius of 20 km. [\[Solution\]](#)

Day 20

Consider a flat and matter-dominated universe, in this case, the age of the universe can be modeled as

$$t = \frac{2}{3H_0} a^{\frac{3}{2}}$$

If the current temperature of the universe is 2.73 K, calculate the duration for which the universe will have a temperature between 0° C and 100° C !

Use $H_0 = 70 \text{ km/s/Mpc}$. [\[Solution\]](#)

Day 21: PoTW 3

An asteroid is at a distance of 625000 km from the Earth and it is initially not in motion relative to the Earth. To prevent the asteroid from falling to the Earth, Bombom planted a nuclear explosive at the center of the asteroid and proceeded to use the device to explode the asteroid such that the asteroid is shattered isotropically into small pieces that moved radially in every direction with the same velocity of 0.5 km/s. [\[Solution\]](#)

- Find how much of the asteroid would still hit the Earth.
- Find how much of the Earth's surface still got hit by the asteroid chunks.
- What shape is formed by the envelope of all of the pieces' orbit?

4 Week 4

Day 22

An asteroid orbits the Sun with an eccentricity of 0.7. The asteroid's rotation is fast enough so that the temperature is homogeneous, and the asteroid can also be considered a black body. If the maximum temperature of this asteroid is 250 K, then the minimum surface temperature of this asteroid is... [\[Solution\]](#)

Day 23

A star with absolute magnitude 2.31^m is at a distance of 1.5 kpc. Due to absorption of interstellar matter, this star has a magnitude of 14.59^m when seen from Earth. If interstellar matter (a collection of dust particles) between the star and the observer is evenly distributed and the size of the dust is about $0.3 \mu\text{m}$, determine the average density of dust particles in that viewing direction. Ignore the scattering effect. [\[Solution\]](#)

Day 24

Due to light aberrations, the coordinates observed in the moving frame will shift compared to the stationary frame. As a result of the Earth's revolution, the observed coordinates of the Sun will shift. Determine the Sun's ecliptic longitude as observed on Earth at the summer solstice. [\[Solution\]](#)

Day 25

Assuming Earth and Mars' orbits are both circular, calculate the minimum phase of Mars as seen from Earth. [\[Solution\]](#)

Day 26

Hydrogen a line from an object is observed on 7500 \AA . If the redshift fully came from the object's peculiar motion, calculate its radial velocity! [\[Solution\]](#)

Day 27

Determine the sunset duration for an observer at the North Pole. [\[Solution\]](#)

Day 28: PoTW 4

On October 7th, Bombom found a new asteroid that is at the coordinate $\lambda = 30^\circ$, $\beta = 0^\circ$. As seen from the Earth, the angular diameter of that asteroid is $0.275''$ and from 2 PM until 5 PM, the asteroid has drifted $90''$ to the West relative to the fixed star on the ecliptic plane. Bombom also uses radar with a frequency of 100 MHz, and he detects its reflection 21 minutes later at a frequency of 99.9963 MHz. From photometric observation, the magnitude of the asteroid is 10.52. [\[Solution\]](#)

- Calculate the distance of that asteroid from the Sun at that time.
- Calculate the asteroid's heliocentric velocity at that time.
- Find the semimajor and eccentricity of the asteroid's orbit.
- Assuming the asteroid is spherical, and its reflection is isotropic, calculate its albedo.
- Compute its average surface temperature when it is closest to the Sun.

5 Week 5

Day 29

Within a certain galaxy, a star is orbiting the center of the galaxy with a perfectly circular orbit at a distance of 10 kpc, and it is also known that the orbital velocity of this star is 300 km/s. If it is known that the luminosity of this galaxy is $4 \times 10^{10} L_{\odot}$, determine its *mass-to-light ratio*.

(State your answer in M_{\odot}/L_{\odot}) [\[Solution\]](#)

Day 30

Jupiter's Great Red Spot has an angular diameter of 1.5 arcminutes. If the spot is photographed with a [60 cm, $f/18$] diameter telescope, what is the size of the image on the plate? [\[Solution\]](#)

Day 31

At a certain moment, Mars appeared to be exactly at the first point of Aries. At that time, Mars was also located in the Eastern quadrature. The next day, how far will Mars deviate from the first point of Aries? [\[Solution\]](#)

Day 32

A certain hypothetical spiral galaxy contains only Sun-like stars. We are within that galaxy, and we measure that our solar system's orbital velocity around the disk is about 220 km/s, our distance to the center of the galaxy is about 8 kpc, and the thickness of the disk is about 0.5 kpc, determine the Schwarzschild Radius of the supermassive black hole.

Assume that the average number density is around 0.495 stars per parsec and is homogenous. [\[Solution\]](#)

Day 33

Sally owns a telescope, and after further observations, she concluded that the diameter of the beam that comes out of the eyepiece is the same as her pupil's diameter, which is 5 mm.

Telescope Specifications

- $D = 400$ mm
- $d_{\text{telescope}} = 1620$ mm

CCD Specifications

- Size = $2160 \text{ px} \times 2160 \text{ px}$
- Pixel Size = $9 \mu\text{m} \times 9 \mu\text{m}$

One day, Sally bought a CCD with the specifications above, and she took off the eyepiece that she previously had and swapped it out for the CCD. Using a Solar Filter, determine how many pixels were activated when Sally pointed her telescope at the Sun. (Assume that the entire Sun is within the scope of her telescope.)

Note: $d_{\text{telescope}}$ is the distance between the two lenses, the object lens, and the eyepiece lens. [\[Solution\]](#)

Day 34

Determine the length and direction of the shadow that is cast by the Tower of Pisa ($43^{\circ}43'23''$ N, $10^{\circ}23'47.10''$ E) on the 19th of October, 1 hour before the Sun sets. It is known that the Tower of Pisa is 52 meters in length and it is tipping towards the North by 5.5° . [\[Solution\]](#)

Day 35: PoTW 5

Bombom places three identical objects with mass M at the corners of an equilateral triangle, each separated by a distance of R . [\[Solution\]](#)

- Then Bombom gave them all an initial velocity of v_o so that all of them were orbiting their center of mass in a circular orbit. Determine the value of v_o and the period of the system!
- If the initial velocity was $0.5 v_o$ instead, all of them would have an elliptical orbit. Find the period of the system, and also determine its eccentricity.

6 Week 6

Day 36

Assume a flat Universe, and Hubble constant of 70 km/s/Mpc, Determine the energy density. [\[Solution\]](#)

Day 37

On the 4th of August 2066, we developed a telescope with enough resolution to see other star systems as clearly as we can see ours. The first-ever trial for this telescope was on a solar system named FJX-1392. The first observation was of an unidentified object, assumed as a satellite orbiting the parent star for 2 years. A couple of years after the initial observation, we see that the same object is now in a different orbit with a period of 5 years. It is speculated that an alien lifeform is controlling the satellite and changed its orbital period.

Determine how much time did that satellite take to perform the orbit transfer, assuming that the maneuver used was a Hohmann Maneuver. [\[Solution\]](#)

Note. that the satellite is first on a circular orbit, and transferred to a different circular orbit, with a different orbital period

Day 38

Sir Nodnod is living on a planet within a certain star system, it is known that the orbital period of this planet around its parent star is 36.05 years, and its orbital radius is 100 AU. Suddenly, the star collapsed into a black hole. Determine its density. [\[Solution\]](#)

Note. The mass of the star is conserved.

Day 39

A binary star system has an inclination of 0° , given that its maximum separation angle is $6''$, and its minimum separation angle is $1.5''$. Determine its orbital eccentricity. [\[Solution\]](#)

Day 40

Determine the velocity of an asteroid that is 30% into its revolution period, given that its semimajor axis and eccentricity are 1.6 AU and 0.57, respectively. [\[Solution\]](#)

Note. The revolution period begins at perihelion.

Day 41

Determine the phase (%) of the moon, 8 days before the full moon. [\[Solution\]](#)

Day 42: PoTW 6

Suppose Bombom is living in a Universe that is filled by radiation only. This Universe is expanding with Hubble constant H_0 , and its temperature at the present is T_0 . [\[Solution\]](#)

- Find the condition for H_0 in terms of T_0 so that this universe has: flat curvature ($\kappa = 0$), positive curvature ($\kappa = 1$), and negative curvature ($\kappa = -1$).
- Find the radius of curvature at the present (R_0).
- Find the age of the universe (t_0) in terms of radiation density parameter (Ω_0) and H_0 .
- Using $H_0 = 70$ km/s/Mpc and $T_0 = 2.73$ K calculate R_0 , t_0 , and also the temperature of the universe at $t = t_0/2$.

7 Week 7

Day 43

Given the average temperature in space is T_{space} , and the average cooked chicken temperature is T_{eat} , assume a cylindrical chicken drumstick.

The cylindrical chicken is in space, at a distance d from the Sun. How long does it take for a chicken drumstick to be cooked? The diameter of the drumstick is D . Assume an average density of ρ_{chicken} , a specific heat capacity of C_{chicken} , and the chicken does not re-emit any radiation.

The orientation of the drumstick is such that it exposes the drumstick to the largest projected area and Also assumes almost instantaneous heat transfer so that its temperature is always uniform. [Solution]

Day 44

Consider a flat and matter-dominated universe. At a certain time t , the universe, instead of expanding at a rate of H_0 , shrank at a rate of $H_0 = 67.4 \text{ km/s/Mpc}$. The current average temperature of the universe is 2.73 K, which determines the amount of time that it takes for the universe to shrink such that the average temperature of the universe is 273 K. [Solution]

Day 45

A star at $[\alpha = 30^\circ, \delta = +20^\circ]$ is observed to have its hydrogen alpha H_α spectral line shift by $+2.85 \text{ \AA}$, and it is also observed to have a proper motion with a position angle of $63^\circ 1' 47.02''$. Due to the proper motion, the right ascension of the star increases by $0.01''/\text{year}$. It is also known from the records that this star has a parallax value of $0.02''$. Determine its true velocity. [Solution]

Day 46

An observer at a latitude of 30°N observed a star rising on the horizon at $Az = 50^\circ$ to determine its azimuth and altitude when the hour angle of that star is $3^{\text{h}5^{\text{m}}}$. [Solution]

Day 47

The radius of the Earth and the Moon are $R_\oplus = 6378 \text{ km}$ and $R_{\text{moon}} = 1737 \text{ km}$. The mass of the Earth and the Moon are $M_\oplus = 5.97 \times 10^{24} \text{ kg}$ and $M_{\text{moon}} = 7.35 \times 10^{22} \text{ kg}$. Determine the Roche limit between the Earth and the Moon. [Solution]

Day 48: APAO 15

According to scientists' estimations, there are about 1800 galaxies in the cluster of galaxies in the constellation Coma Berenices, which show a redshift of 0.023. The region in our sky covered by this cluster is about 90 degrees². Estimate the average distance between the galaxies in this cluster. [Solution]

Day 49: PoTW 7

Within a corner of the Backrooms, Bombom is eating an ice cream on a table (**Point B**). Measured from one of the corners (**Point O**), Bombom is at coordinate (x, y, z) . From Bombom's point of view, the edge of the x axis and the edge of the z axis will form an obtuse angle θ as seen on the image below. Derive an expression for θ in terms of $x, y,$ and z . [Solution]

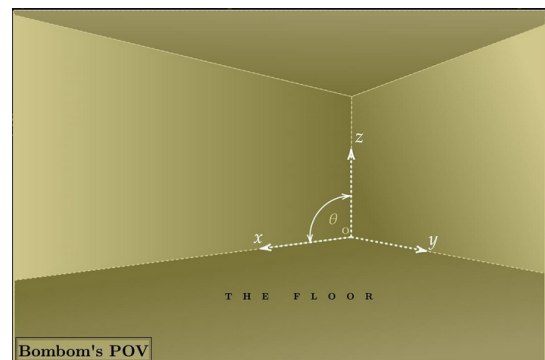
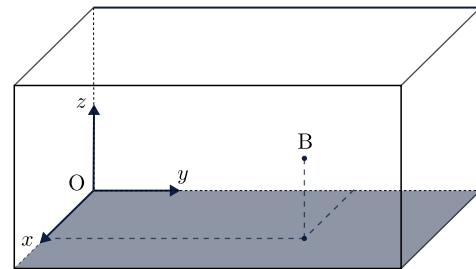

8 Week 8

Day 50

One of the most common things used by Hellenistic and Western astrology is the birth chart/natal chart. This chart has three parts: Planets, zodiac signs, and houses. We divide the ecliptic plane into twelve equal parts called houses, with the 1st house at the ascendant (the zodiac sign rising at that time), and the 2nd house next to the 1st house (measured westward). These are the interpretations of all houses, planets, and signs.

TWELVE HOUSES	THE PLANETS	THE ZODIAC SIGN
1st House: Physical Appearance	The Sun: Purpose	Aries: Passion
2nd House: Money	The Moon: Emotion	Taurus: Loyalty
3rd House: Friends	Mercury: Mind	Gemini: Curiosity
4th House: Family	Venus: Value	Cancer: Creativity
5th House: Children	Mars: Motivation	Leo: Courage
6th House: Health	Jupiter: Luck	Virgo: Organization
7th House: Marriage	Saturn: Maturity	Libra: Justice
8th House: Transformation	Uranus: Innovation	Scorpio: Power
9th House: Education	Neptune: Dreams	Sagittarius: Adventure
10th House: Career	Pluto: Rebirth	Capricorn: Ambition
11th House: Humanitarianism		Aquarius: Innovation
12th House: Spirituality		Pisces: Imagination

Table 1: Reading Example: If when you are born, Mars is in Taurus in the third house, this means you will be motivated (Mars) through loyalty (Taurus) of interpersonal relationships (3rd house).

One day, Bombom's friend is planning to have a baby with these perks:

“Have a strong purpose through ambition for having lots of money.” If he is at latitude 30° N, find the date and time (local time) of the birth so that the baby has those perks. [\[Solution\]](#)

Day 51

Determine the longest and shortest wavelength of the Balmer Series. [\[Solution\]](#)

Day 52

Determine the duration for which the sun is above the horizon for an observer at 35° N, on the 17th of July. Ignore atmospheric refractions. [\[Solution\]](#)

Day 53

It is known that Sir Nodnod has to sleep 8 hours a day, and on 4th of April 2024, 22:56 LT, he is still making a PoTD Problem. Given that the illumination phase of the Moon is currently 0.23, determine the phase of

the Moon when Sir Nodnod wakes up in the morning. [\[Solution\]](#)

Day 54

Given a comet is orbiting the sun with

$$\vec{v} = \begin{pmatrix} 50 \\ 24 \\ 2 \end{pmatrix} \text{ km/s,}$$

and is at

$$\vec{r} = \begin{pmatrix} 10 \\ 2 \\ 14 \end{pmatrix} \text{ AU.}$$

Determine the inclination of the orbit. [\[Solution\]](#)
Note: the xy plane makes the plane of the ecliptic.

Day 55

Determine the number of photons in the visible spectrum that pass through a telescope every second it observes Sirius. It is known that the diameter of the telescope is 96 mm wide, and the magnitude of Sirius when observed with the naked eye is 1.46. [\[Solution\]](#)

Day 56: PoTW 8

Bombom is observing an elliptical galaxy at redshift $z = 1.25$.

[Solution]

From photometric observation, its apparent magnitude is $m = -22.75$.

From spectroscopic observation, its radial velocity dispersion is $\sigma_r = 220$ km/s.

From astrometric observation, its angular diameter is $\theta = 6.5''$.

If Bombom lives in a flat, matter-dominated universe, with Hubble Constant $H_0 = 70$ km/s/Mpc,

- Calculate the galaxy's proper distance, angular diameter distance, and luminosity distance.
- Calculate the luminosity of the galaxy.
- Calculate the mass of the galaxy (Virial mass). Assume that the elliptical galaxy is spherical with uniform mass distribution.
- Calculate the mass-to-light ratio (M/L) in terms of M_\odot/L_\odot .

9 Week 9**Day 57**

Determine the Thermal Time Scale of the Sun. [Solution]

Day 58

When Venus is at an elongation 20° , determine its distance from the Earth. [Solution]

Day 59

Determine the limiting magnitude of a telescope that has a focal ratio of 20 mm and a focal length of 1600 mm. [Solution]

Day 60

The flux density of the sun on the frequency $f = 110$ MHz is Jy . Determine the amount of photons that a 10 m radio telescope will receive if it were to observe the sun for 10 seconds on $f = 108$ MHz til $f = 112$ MHz. [Solution]

Day 61

An electron is moving with a constant velocity of $0.6c$. Determine the kinetic energy and the momentum of the electron. [Solution]

Day 62

Determine the maximum eccentricity of an asteroid's orbit entirely within the Goldilocks zone. [Solution]

Day 63: PoTW 9

Initially a spacecraft is orbiting the Sun at orbital radius r_1 . This spacecraft can go to any other circular orbit with radius r_2 (with $r_2 > r_1$) using Hohmann transfer, that is by using transfer orbit which is tangent to the initial and final orbit. [Solution]

- Total impulse needed to the orbital transfer is Δv , and we denote y as $y = \Delta v/v_1$, and x as $x = r_2/r_1$. Write an expression for y as a function of x .
- Find the maximum value for y and the corresponding x value. Also, calculate the maximum Δv and the corresponding r_2 if the initial orbit is the Earth orbit.
- Bombom is making a spacecraft. The structure of the spacecraft is 20 tons, it carries 500 tons of fuel, and the exhaust velocity of the thruster is 5000 m/s. Could this spacecraft access all possible circular orbit ($r_2 > r_1$) using Hohmann transfer? If yes, calculate the maximum payload it could carry so that it could still access all the possible orbits. For this problem, just consider the heliocentric orbit (neglecting Earth's gravity).

10 Week 10

Day 64

Determine today's (April 15th, 14 UT) Julian Date. [\[Solution\]](#)

Day 65

The precession of the Earth's rotation axis causes the ecliptic longitude to change linearly but the ecliptic latitude remains constant. Given that Earth's precession period is 26,000 years, determine what the equatorial coordinates of Arcturus ($14^h 16^m$, $19^\circ 5'$) will be in 9000 years. In this case, assume that obliquity is constant. [\[Solution\]](#)

Day 66

The hydrostatic equilibrium within the Sun can be expressed with the following expression

$$\frac{dP}{dr} = -\frac{GM(r)}{r^2} \rho$$

Assuming that the density within the Sun is homogeneous, hence determine the pressure within the core of the Sun. [\[Solution\]](#)

Day 67

An astronomer is trying to find the distance of 2 stars, all he has is the 2 stars' coordinates in 3D space relative to his position. Star **A** has coordinates (30, 23, 12) pc, and Star **B** has coordinates (34, 12, 19) pc. [\[Solution\]](#)

Day 68

If it is known that the planet Miller from the movie *Interstellar* (2014) is orbiting around a Supermassive Blackhole (SMBH) named Gargantua at $r = 2.97$ AU, and it was stated in the movie that the gravitational time dilation effect was so extreme that 1 hour spent on the planet equates to roughly 7 years on Earth.

Determine the mass of Gargantua. [\[Solution\]](#)

- The formula to determine gravitational time dilation within a circular orbit is

$$t = \frac{t_0}{\sqrt{1 - \frac{3r_s}{2r}}}$$

Where t is the time experienced by a far observer, so is the time experienced by an observer within a strong gravitational field, and r_s is the Schwarzschild radius.

Day 69

A sorcerer accidentally cast a spell that made the Sun shrink, shrinking it by a factor of 4. Determine the Sun's new apparent magnitude. [\[Solution\]](#)

Note. Assume constant temperature.

Day 70: PoTW 10

A star with a radius of $4 R_\odot$ is observed at 4000 \AA with a bandwidth of 500 \AA . The star's parallax is $0.08''$, and its peak radiation is at 8000 \AA . The observation is done with a $2.5 m$ telescope, a CCD with a quantum efficiency of 70%, and 25 seconds of exposure time. [\[Solution\]](#)

- Determine the star's temperature and determine whether we could use Wien's Approximation for the observation wavelength or not.
- Determine the luminosity of the star on the observed wavelength.
- Determine the photon count for the setup mentioned above.
- If we take into account the intrinsic noise from the instrument, determine the uncertainty of the photon count, as well as the signal-to-noise ratio (S/N).
- Determine the exposure time needed to double the Signal-to-Noise ratio.

11 Week 11

Day 71

Given that the hydrogen particles within the Sun's Corona have a velocity of 160 km/s, determine the temperature of the Sun's Corona. [\[Solution\]](#)

Day 72

Determine the minimum inclination of a binary star whose two stars are like the Sun and are 1 AU apart from each other, to appear as an eclipsing binary star. [\[Solution\]](#)

Day 73

Derive and determine the Roche limit of the Sun, with respect to the Earth. [\[Solution\]](#)

Note. Assume Earth is a rigid body.

Day 74: 3rd IOAA, Iran 2009

Calculate how much the radius of the Earth's orbit increases as a result of the Sun losing mass due to the thermonuclear reactions in its center in 100 years. Assume the Earth's orbit remains circular during this period. [\[Solution\]](#)

Day 75

Determine the size of the projection of the Sun on a piece of paper 1.5 meters away from the eyepiece of a telescope. The telescope has a focal length of 900 mm, and the eyepiece has a focal length of 10 mm, the diameter of the telescope is 30 mm. [\[Solution\]](#)

Day 76

Determine the weight of the average adult (70 kg) if the Earth was hollow with a thickness of 10 km. [\[Solution\]](#)

Day 77: PoTW 11

An asteroid orbital velocity is $\vec{v} = -14\hat{i} + 5\hat{j} + 2\hat{k}$ km/s when it is at position $\vec{r} = 2\hat{i} - \hat{j} + \hat{k}$ AU. Calculate its semi-major (a), eccentricity (e), orbital inclination (i), longitude of ascending node (Ω), and argument of perihelion (ω) of that asteroid. (\hat{i} is the direction of vernal equinox, and \hat{k} is in the direction of the North Ecliptic Pole)

12 Week 12

Day 78

Determine the maximum value of Doppler shift we would expect from a binary system where both stars are Sun-like and is 5 AU apart from each other. Assume that the barycenter of the system is stationary relative to us and in a circular orbit. [\[Solution\]](#)

Day 79

On some days, the Moon is visible during the day, and on some, it's not even visible during the night. This is due to the fact that the Moon goes through phases in its orbit. Determine the duration in the Moon's orbit from the point of the first quarter to the third, passing the Full Moon phase; Determine also the time from the third quarter to the first, passing the New Moon phase. Determine the ratio between the two durations. [\[Solution\]](#)

Note. $e_{\text{moon}} = 0.0549$, $a = 384.748$ km.

Day 80

Determine what day is the 21st of October 451227, given that the 31st of May, 2024 is a Friday. [\[Solution\]](#)

Day 81

A star cluster has main-sequence stars of spectral type **B7** (surface temperature around 13,000 K, radius around 3.28 solar radii) turning off the main sequence. Estimate the age of this star cluster. [\[Solution\]](#)

Day 82

Consider two neutron stars, both having a mass of $1.4 M_{\odot}$. They are both in a circular orbit around a barycenter and both are initially 100 km apart. Determine the amount of time that it takes for them to collide due to their emission of gravitational waves. [\[Solution\]](#)

Note. The rate of orbital decay due to gravitational wave emissions may be approximated using the following expression

$$\frac{dr}{dt} = -\frac{64 G^3 (m_1 m_2)(m_1 + m_2)}{5 c^5 r^3}$$

Day 83

Consider the Summer Triangle. Draw three edges such that all the stars within the previously mentioned asterism act as their vertices, effectively creating a spherical triangle. Determine the solid angle of this triangle.

Below are the equatorial coordinates of the stars in the asterism:

- α *Lyr* ($18^h 36^m$, $+38^\circ 47'$)
- α *Cyg* ($20^h 41^m$, $+45^\circ 16'$)
- α *Aql* ($19^h 50^m$, $+08^\circ 52'$)

13 Solutions

★ Solution of Day 1 ★

Check Problem Description: Day 1.

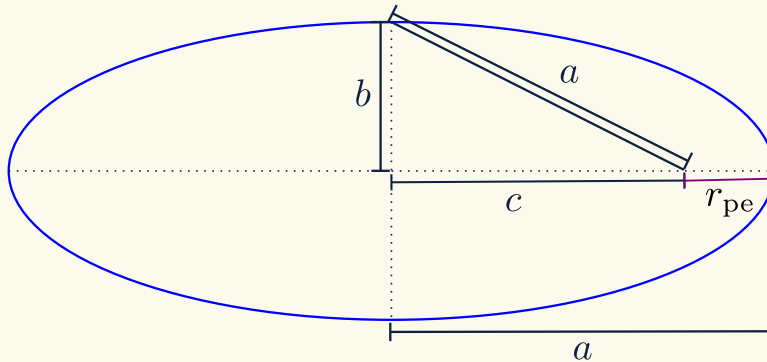

Given,

1. $M_{\star} = 2 M_{\odot}$
2. $a = 0.8 \text{ AU}$,
3. $b = 0.6 \text{ AU}$.

Using simple Pythagoras in the ellipse,

$$\begin{aligned} a^2 &= b^2 + c^2 \\ c^2 &= a^2 - b^2 \\ c &= 0.529 \text{ AU} \end{aligned}$$

Now, the distance of the periastron,

$$\begin{aligned} r_{pe} &= a - c \\ &= 0.271 \text{ AU} \end{aligned}$$

From Vis-visa equation,

$$\begin{aligned} v &= \sqrt{2GM_{\star} \left(\frac{1}{r_{pe}} - \frac{1}{2a} \right)} \\ v &= 104.48 \text{ km/s} \end{aligned}$$

★ Solution of Day 2 ★

Check Problem Description: Day 2

We know,

$$\begin{aligned} p'' &= \frac{1}{d \text{ (pc)}} \implies d \text{ (pc)} = \frac{1}{p''} \\ d &= 33.3 \text{ pc} \end{aligned}$$

★ Solution of Day 3 ★

Check Problem Description: Day 3

Given,

- | | | |
|---|---------------------------------------|---|
| 1. $d_{\text{sirius}} = 8.6 \text{ ly}$, | 3. $m_{\odot} = -26.8^m$, | 5. $R_{\odot} = 6.96 \times 10^8 \text{ m}$, |
| 2. $R_{\text{sirius}} = 1.71 R_{\odot}$, | 4. $S_{\odot} = 1370 \text{ W/m}^2$, | 6. $m_{\text{sirius}} = -1.61^m$. |

Question: T_{sirius} ?

Answer:

$$L_{\odot} = 4\pi R_{\odot}^2 \sigma T_{\odot}^4$$

$$S_{\odot} = \frac{L_{\odot}}{4\pi d^2} = \frac{4\pi R_{\odot}^2 \sigma T_{\odot}^4}{4\pi d^2} = \frac{R_{\odot}^2 \sigma T_{\odot}^4}{d^2}$$

$$m_{\text{sirius}} - m_{\odot} = -2.5 \log \left(\frac{E_{\text{sirius}}}{S_{\odot}} \right)$$

$$\frac{E_{\text{sirius}}}{S_{\odot}} = 8.39 \times 10^{-11}$$

$$\frac{R_{\text{sirius}}^2 \sigma T_{\text{sirius}}^4}{d_{\text{sirius}}^2} \cdot \frac{d^2}{R_{\odot}^2 \sigma T_{\odot}^4} = 8.39 \times 10^{-11}$$

$$\left(\frac{T_{\text{sirius}}}{T_{\odot}} \right)^4 = 8.45$$

$$\boxed{T_{\text{sirius}} = 1.7 T_{\odot}}$$

★ Solution of Day 4 ★

Check Problem Description: Day 4

Given,

1. $H_0 = 70 \text{ km/s/Mpc}$,
2. $T_0 = 2.73 \text{ K}$,
3. $\Omega_{m,0} = 0.25$,
4. $\Omega_{r,0} = 8.4 \times 10^{-5}$,
5. $T_{\text{rcmb}} = 3000 \text{ K}$,
6. Flat Universe $\implies \Omega = 1$

Question: What is the value of the Hubble parameter (H) at the time of recombination?

Solution:

Step 1

Calculate the Scale factor (a) at the time of recombination.

$$T = \frac{T_0}{a} \implies a = \frac{T_0}{T} = 9.1 \times 10^{-4}$$

Step 2

Calculate the current amount of dark energy

$$\Omega = \Omega_{m,0} + \Omega_{r,0} + \Omega_{\Lambda,0} = 1$$

$$\boxed{\Omega_{\Lambda,0} = 7.5 \times 10^{-1}}$$

Step 3

Making H as a function of scale factor (for the flat universe, $\rho = \rho_c$)

$$\rho = \rho_c = \frac{3H^2}{8\pi G}$$

$$H^2 = \frac{8\pi G}{3} \rho$$

$$\frac{H^2}{H_0^2} = \frac{8\pi G}{3H_0^2} (\rho_m + \rho_r + \rho_{\Lambda})$$

$$\frac{H^2}{H_0^2} = \frac{1}{\rho_{c,0}} (\rho_{m,0} \cdot a^{-3} + \rho_{r,0} \cdot a^{-4} + \rho_{\Lambda,0})$$

$$\frac{H^2}{H_0^2} = \Omega_{m,0} \cdot a^{-3} + \Omega_{r,0} \cdot a^{-4} + \Omega_{\Lambda,0}$$

$$\boxed{H = 4.82 \times 10^{-14} / \text{s} = 1.49 \times 10^6 \text{ km/s/Mpc}}$$

★ Solution of Day 5 ★

Check Problem Description: Day 5

Given,

1. $\lambda_{\max} = 410 \text{ nm}$
2. $H_{\alpha} = 842 \text{ nm}$
3. $R = 1.0974 \times 10^7 \text{ m}^{-1}$

Question: What is the value of surface brightness S (in terms of mag/arcsec²).**Solution:****Step 1**Calculate the H_{α} line at the resting condition,

$$\frac{1}{H_{\alpha,0}} = R \left(\frac{1}{2^2} - \frac{1}{3^2} \right)$$

$$H_{\alpha,0} = 656.47 \text{ nm}$$

Step 2

Calculate the redshift,

$$z = \frac{H_{\alpha} - H_{\alpha,0}}{H_{\alpha,0}}$$

$$z = 0.2826$$

Step 3

Calculate the peak wavelength at the resting condition

$$z = \frac{\lambda_{\max} - \lambda_{\max,0}}{\lambda_{\max,0}}$$

$$\frac{\lambda_{\max}}{\lambda_{\max,0}} = 1 + z$$

$$\lambda_{\max,0} = 319.66 \text{ nm}$$

Step 4

Calculate the Star's surface temperature,

$$b = \lambda_{\max,0} T$$

$$T = \frac{b}{\lambda_{\max,0}}$$

$$T = 9065.96 \text{ K}$$

Step 5Calculate the Surface brightness (B)

$$B = \frac{\sigma T^4}{\pi}$$

$$B = 1.23 \times 10^8 \text{ W/m}^2/\text{sterad}$$

$$B = 2.87 \times 10^{-3} \text{ W/m}^2/\text{arcsec}^2$$

Step 6Calculate the Surface brightness (S)

$$S - m_{\odot} = -2.5 \log \left(\frac{B}{S_{\odot}} \right)$$

$$S = -12.6 \text{ mag/arcsec}^2$$

★ Solution of Day 6 ★

Check Problem Description: Day 6

Given,

1. $\alpha_{\text{rigel}} = 05^{\text{h}}14^{\text{m}}32.3^{\text{s}}$
2. $\delta_{\text{rigel}} = -0.8^{\circ}12'05.9''$
3. $\phi_{\text{obs}} = -37^{\circ}50'27.3660''$
4. $\lambda_{\text{obs}} = 144^{\circ}56'47.2452'' \text{ E}$
5. Date: 10th April
6. $a_{\text{rigel}} = 0^{\circ}$

Question: Civil time and Azimuth when Rigel rises.

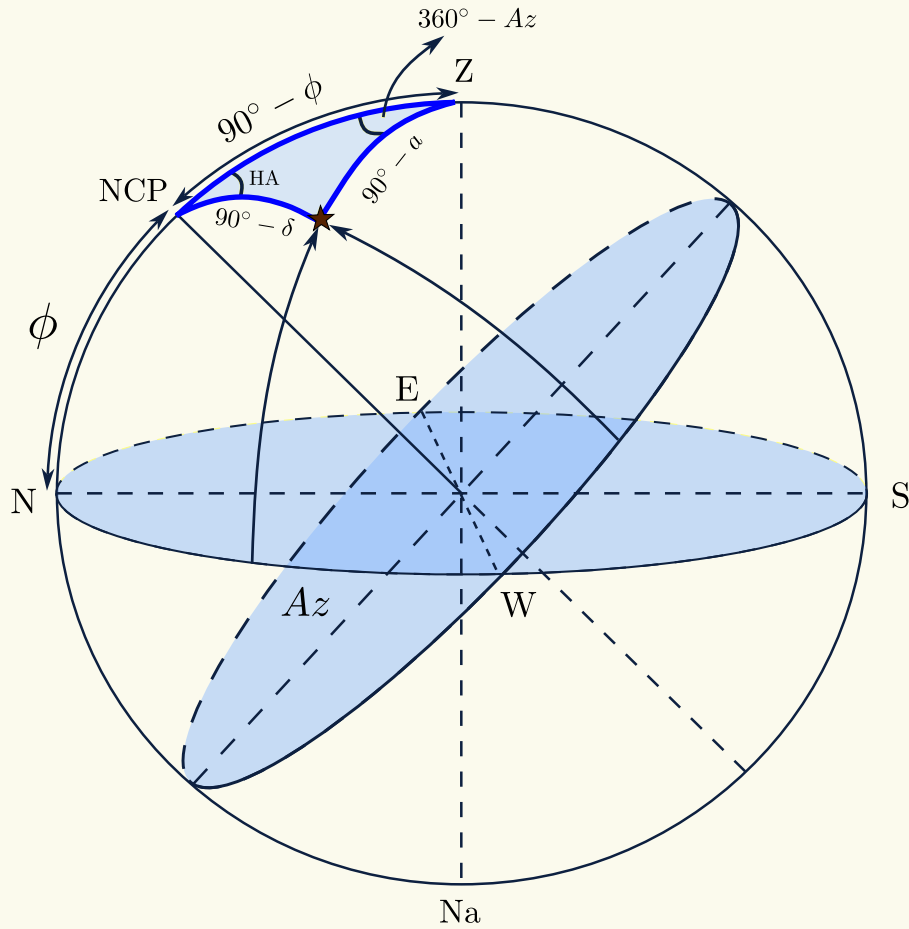

From Sunrise Equation,

$$\cos HA_{\text{rigel}} = -\tan \delta_{\text{rigel}} \tan \phi_{\text{obs}}$$

$$HA_{\text{rigel}} = 6^{\text{h}}25^{\text{m}}42.86^{\text{s}}$$

Below n is measured from Vernal Equinox.

$$\lambda_{\odot} = \frac{n}{365.25} \times 360^{\circ}$$

$$\lambda_{\odot} = 19^{\circ}42'45.09''$$

$$\tan \alpha_{\odot} = \cos \varepsilon \tan \lambda_{\odot}$$

$$\alpha_{\odot} = 18^{\circ}11'22.39'' = 1^{\text{h}}12^{\text{m}}45.49^{\text{s}}$$

Using Local Sidereal Time relation,

$$LST = HA + \alpha$$

$$LST = HA_{\text{rigel}} + \alpha_{\text{rigel}} = 11^{\text{h}}40^{\text{m}}14^{\text{s}}$$

$$LST = HA_{\odot} + \alpha_{\odot} \implies HA_{\odot} = 10^{\text{h}}27^{\text{m}}29.72^{\text{s}}$$

$$LT = HA_{\odot} + 12^{\text{h}} \implies LT = 22^{\text{h}}27^{\text{m}}29.72^{\text{s}}$$

$$CT = LT - \frac{\lambda_{\text{obs}} - \lambda_{\text{timezone}}}{15} = \boxed{19^{\text{h}}7^{\text{m}}16.87^{\text{s}}}$$

Using cosine law,

$$\sin \delta = \sin \phi \sin a + \cos \phi \cos a \cdot \cos Az$$

$$\cos Az = \frac{\sin \delta - \cancel{\sin \phi \sin a}}{\cos \phi \cos a} = \frac{\sin \delta}{\cos \phi} [\because a = 0]$$

$$\boxed{Az = 100^{\circ}24'26.08''}$$

★ Solution of Day 7 ★

Check Problem Description: Day 7

From the graph, we are able to deduce that the values of α and δ are to be expressed in terms of (x, y, z) . Transformation between Cartesian to Celestial coordinates:

$$x = \cos \delta \cos \alpha, \quad y = \cos \delta \sin \alpha, \quad z = \sin \delta$$

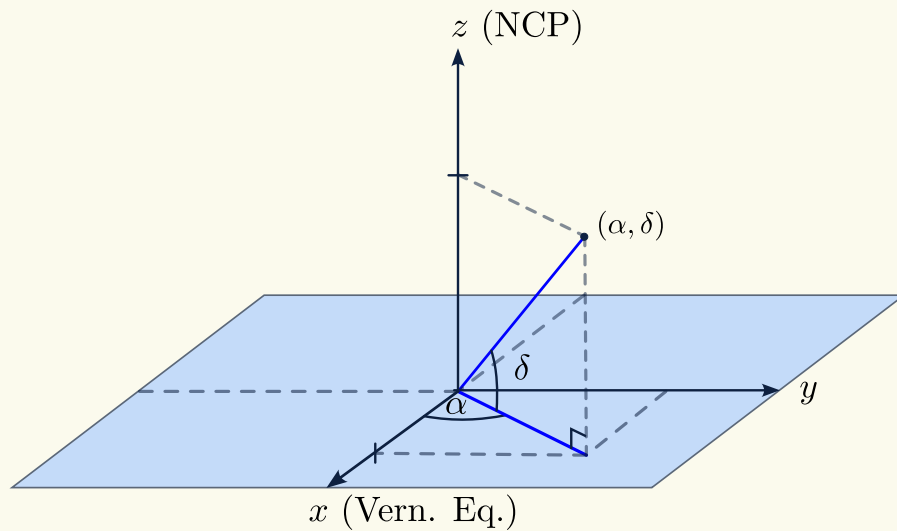

Therefore, we can also express (α, δ) in the standard $(\hat{i}, \hat{j}, \hat{k})$ vector notation. So we can now express the coordinates of 4 stars in vector notation.

- α Peg: $23^h 05^m, 15^\circ 18'$
- β Peg: $23^h 04^m, 28^\circ 11'$
- γ Peg: $0^h 14^m, 15^\circ 17'$
- δ Peg: $23^h 09^m, 29^\circ 11'$

Expressing in vector coordinates:

- $\overrightarrow{\alpha \text{ Peg}}: (0.937\hat{i} - 0.229\hat{j} + 0.264\hat{k})$
- $\overrightarrow{\beta \text{ Peg}}: (0.885\hat{i} - 0.213\hat{j} + 0.472\hat{k})$
- $\overrightarrow{\gamma \text{ Peg}}: (0.963\hat{i} + 0.059\hat{j} + 0.264\hat{k})$
- $\overrightarrow{\delta \text{ Peg}}: (0.872\hat{i} + 0.034\hat{j} + 0.488\hat{k})$

Note. that because the equatorial coordinate system is a direction-wise coordinate system, the r

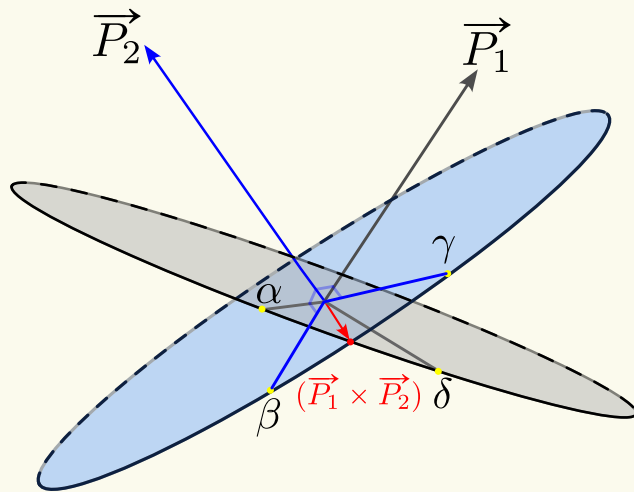

$\overrightarrow{\alpha \text{ Peg}}$ and $\overrightarrow{\delta \text{ Peg}}$, and similarly $\overrightarrow{\beta \text{ Peg}}$ by using cross product of $\overrightarrow{\beta \text{ Peg}}$ and $\overrightarrow{\gamma \text{ Peg}}$.

The intersection of the 2 diagonals made by $\alpha - \delta$ and $\beta - \gamma$, is the cross product of $\overrightarrow{P_1} \times \overrightarrow{P_2}$.

Let \overrightarrow{N} be $\overrightarrow{P_1} \times \overrightarrow{P_2}$.

$$\overrightarrow{N}: (0.111\hat{i} - 0.011\hat{j} + 0.0467\hat{k})$$

Therefore, we are able to deduce the values of α_N and δ_N .

$$\tan \alpha_N = \frac{N_y}{N_x}$$

$$\tan \delta_N = \frac{N_z}{\sqrt{N_x^2 + N_y^2}}$$

A great circle can be perfectly described by using its polar coordinates. The pole of the great circle passing through α_{peg} and δ_{peg} is P_1 , and the pole of the great circle passing through β_{peg} and γ_{peg} is P_2 . We can get $\overrightarrow{P_1}$ by using the cross product of

At last, we have found the value for the intersection, which is $(23^h 36^m, 22^\circ 54')$.

★ Solution of Day 8 ★

Check Problem Description: Day 8

Given,

1. $M_{\star} = 3M_{\odot}$

2. $R_{\star} = 2R_{\odot}$

3. ρ is Homogenous**Question:** Pressure in the core of Star A.**Answer:** Use the *Hydrostatic Equilibrium Equation*,

$$\frac{dP}{dr} = -\frac{GM(r)\rho}{r^2}$$

$$\int_0^{P_{\text{core}}} dP = -G\rho \int_R^0 \frac{M(r)}{r^2} dr$$

$$\int_0^{P_{\text{core}}} dP = -\frac{4}{3}\pi G\rho^2 \int_R^0 r dr$$

$$P = -\frac{2}{3}\pi G\rho^2 (r^2)|_R^0$$

$$P = 7.64 \times 10^{13} \text{ Pa}$$

★ Solution of Day 9 ★

Check Problem Description: Day 9

A. Ophiachus

D. Hercules

B. Serpens Caput

E. Lyra

C. Corona Borealis

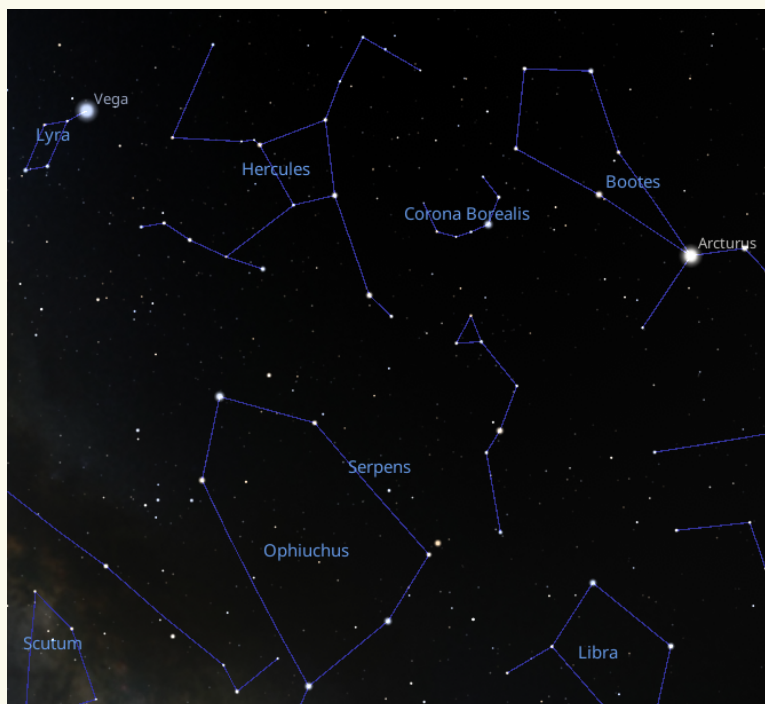

Recommendation: To better understand Observation problems and how to work with star charts, proceed to *Star Charts 101 and Practices* by FAHIM RAJIT HOSSAIN (me).

★ Solution of Day 10 ★

Check Problem Description: Day 10

Given:

1. $l = 34^\circ$,
2. $v_r = 76 \text{ km/s}$.
3. $v_0 = 250 \text{ km/s}$

Question: What is the distance between the Galactic center to the star?

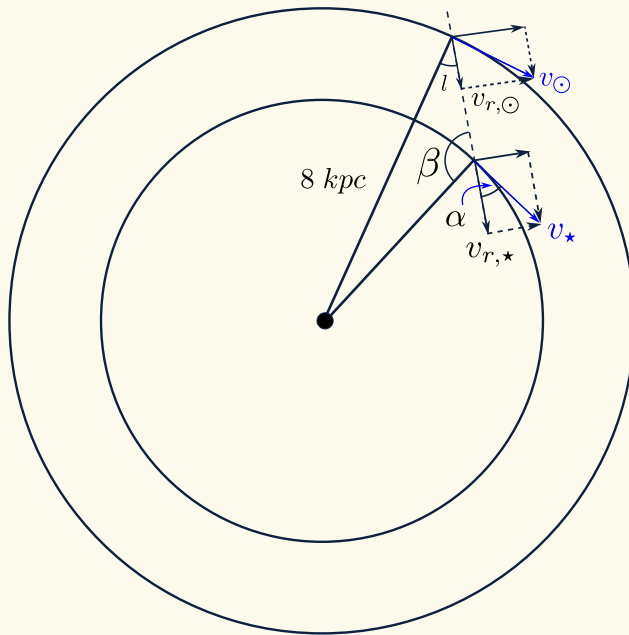

Answer:

$$\begin{aligned}
 v_{\odot} &= v_{\star} = v_0 \\
 v_{r,\odot} &= v_{\odot} \sin l \\
 v_{r,\odot} &= 139.8 \text{ km/s} \\
 v_{r,\text{rel}} &= v_{r,\star} - v_{\odot} \sin l \\
 76 \text{ km/s} &= v_{r,\star} - v_{\odot} \sin l \\
 v_{r,\star} &= 215.8 \text{ km/s} \\
 v_{r,\star} &= v_{\star} \cos \alpha \\
 \cos \alpha &= \frac{v_{r,\star}}{v_{\star}} = \frac{215.8 \text{ km/s}}{250 \text{ km/s}} \\
 \alpha &= 30.32^\circ \\
 \beta &= 180^\circ - (90^\circ - \alpha) \\
 \beta &= 59.68^\circ \\
 \frac{\sin \beta}{8 \text{ kpc}} &= \frac{\sin l}{d_{\star}} \implies d_{\star} = \frac{\sin l \cdot 8 \text{ kpc}}{\sin \beta} \\
 \boxed{d_{\star} = 5.18 \text{ kpc}}
 \end{aligned}$$

★ Solution of Day 11 ★

Check Problem Description: Day 11

Known:

1. $M_{\text{moon}} = 7.35 \times 10^{22} \text{ kg}$,
2. $R_{\text{moon}} = 1737 \text{ km}$.

Answer:

$$F_s + N - F_g = 0$$

The plane will start to lift when the normal force

is equal to 0, and therefore,

$$\begin{aligned}
 F_s &= F_g \\
 \frac{mv^2}{R} &= \frac{GMm}{R^2} \\
 v_{\text{liftoff}} &= \sqrt{\frac{GM_{\text{moon}}}{R_{\text{moon}}}} \\
 \boxed{v_{\text{liftoff}} = 1.68 \text{ km/s}}
 \end{aligned}$$

★ Solution of Day 12 ★

Check Problem Description: Day 12

Given:

1. $M_{BH} = 4 \times 10^6 M_{\odot}$,
2. $d_{GC} = 8 \text{ kpc}$.

Question: In what wavelength should we observe the black hole in?**Answer:** We need the angular distance of the black hole to be smaller than the angular resolution of the telescope. We know the angular resolution,

$$\theta_{\text{tel}} = 1.22 \frac{\lambda}{d}$$

So,

$$\begin{aligned} \theta_{BH} &\geq \theta_{\text{tel}} \\ \frac{2R_{BH}}{d_{GC}} &\geq \frac{\lambda}{2R_{\oplus}} \\ \lambda &\leq \frac{4 \cdot R_{BH} \cdot R_{\oplus}}{d_{GC}} \\ \lambda &\leq \frac{8GM_{BH} \cdot R_{\oplus}}{c_0^2 \cdot d_{GC}} \\ \lambda &\leq 1.224 \times 10^{-3} \text{ m} \end{aligned}$$

We will need to observe in the Radio region.

★ Solution of Day 13 ★

Check Problem Description: Day 13

Given:

1. $m = 9^m$,
2. $M = -25^m$,
3. $\alpha = 0.15 \text{ mag/kpc} = 0.00015 \text{ mag/pc}$.

Answer:

$$\begin{aligned} m - M &= -5 + 5 \log d + \alpha d \\ d &= \frac{m - M + 5 - 5 \log d}{\alpha} \end{aligned}$$

Question: Distance of the Galaxy.Through iteration: $d = 94.2 \text{ kpc}$

★ Solution of Day 14 ★

Check Problem Description: Day 14

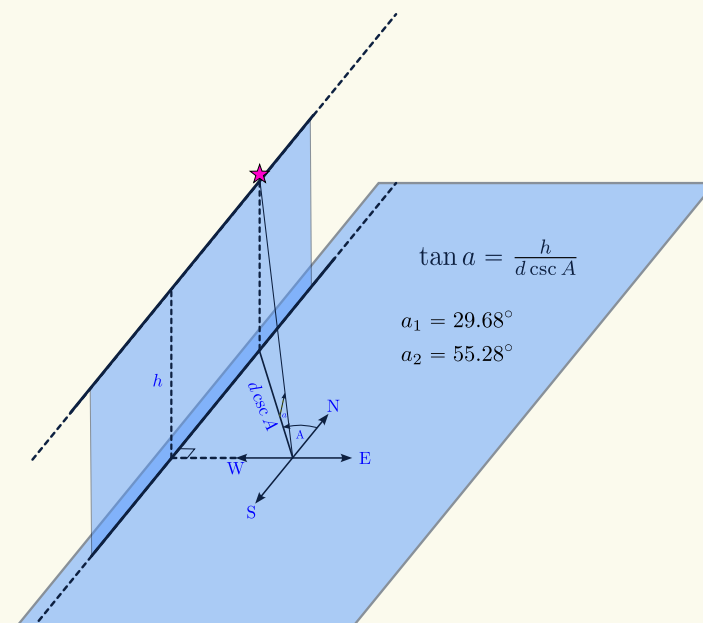

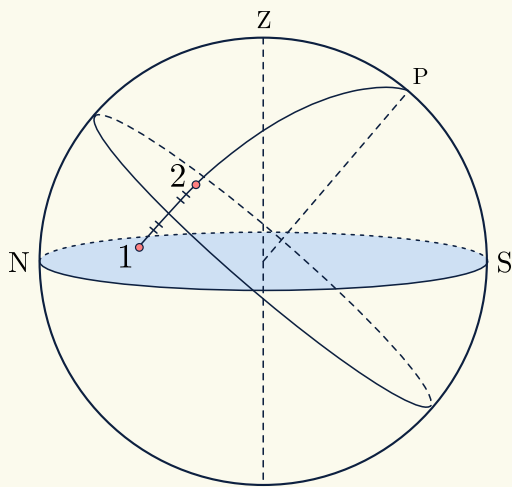
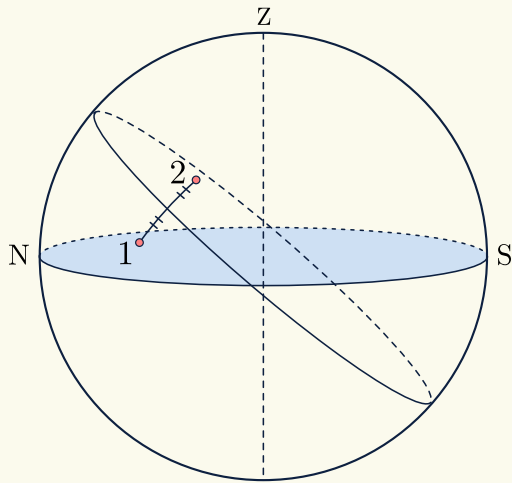

Using spherical triangle Z – Star 1 – Star 2

- $\cos \theta = \sin a_1 \sin a_2 + \cos a_1 \cos a_2 \cos(A_2 - A_1)$
 $\theta = 38.18^\circ$
- $\sin a_2 = \sin a_1 \cos \theta + \cos a_1 \sin \theta \cos \gamma$
 $\gamma = 36.31^\circ$

Using spherical triangle Z – Star 1 – P

- $\sin a_p = \sin a_1 \cdot \left(-\sin \frac{\theta}{2}\right) + \cos a_1 \cos \frac{\theta}{2} \cos \gamma$
 $a_p = 29.97^\circ$

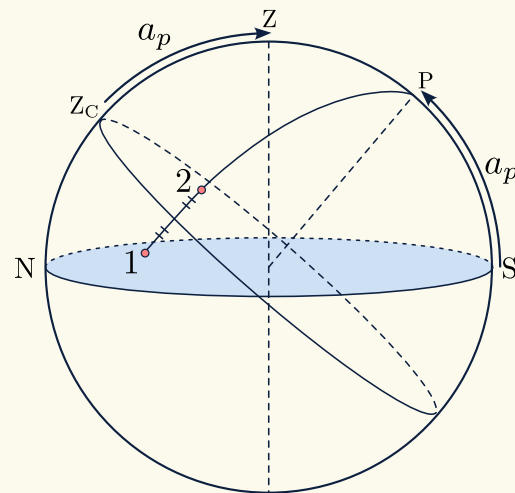
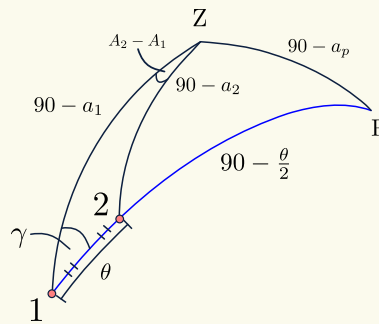

The altitude of the 2 stars would only be the same if their angular distance to the local zenith is the same.

On the celestial sphere, we can map all of the possible zeniths (or you could think of it as mapping all possible locations on Earth) that satisfy the equidistance condition, and the result of the mapping would be of a great circle.

To find the closest location to Alice, we need to find the closest angular distance of Alice’s zenith to the great circle.

First, we should find the pole of the great circle of zenith.

The angular separation of Alice’s Zenith (Z) and the Zenith of the closes location that sees both the stars at the same time (Z_C) is a_p .

Therefore the Geodesic distance is:

$$S = \frac{a_p}{360^\circ} \times 2\pi R_\oplus$$

$$S = 3336.37 \text{ km}$$

★ Solution of Day 15 ★

Check Problem Description: Day 15

Given:

1. $v = 400 \text{ km/s}$,
2. $n_p = 7/\text{cm}^3$,
3. $m_p = 1.6726 \times 10^{-27} \text{ kg}$.

Question: dM_{\odot}/dt due to Solar Wind.**Answer:**

$$n_p = 7 \times 10^6 \text{ proton/m}^3$$

$$\begin{aligned} \text{Proton flux } (\phi_p) &= n_p \times v \\ &= (7 \times 10^6) \times (400,000 \text{ m/s}) \\ &= 2.8 \times 10^{12} \text{ (proton/s)/m}^2 \end{aligned}$$

Number of protons released per second,

$$\begin{aligned} L_p &= \phi_p \times 4\pi d_{\odot}^2 \\ &= 2.8 \times 10^{12} \text{ (proton/s)/m}^2 \times 4\pi(1.5 \times 10^{11})^2 \text{ m}^2 \\ &= 7.92 \times 10^{35} \end{aligned}$$

Since L_p is in *protons/s*, we can write it as $\frac{dM_{\odot}}{dt}$ in *kg/s*

$$\frac{dM_{\odot}}{dt} = L_p \times m_p = \boxed{1.32 \times 10^9 \text{ kg/s}}$$

★ Solution of Day 16 ★

Check Problem Description: Day 16

Given:

1. Offset from the true East = 16° ,
2. Position of the center of the Sun = 23.5° ,
3. Angular radius of the Sun: 0.25° .

Question: What is the minimum value of L .**Answer:** Let θ be the difference in angle from the edge of the Sun's disk to the direction of the house.

$$\theta = \delta_{\odot} + 0.25^\circ - 16^\circ$$

$$\theta = 7.75^\circ$$

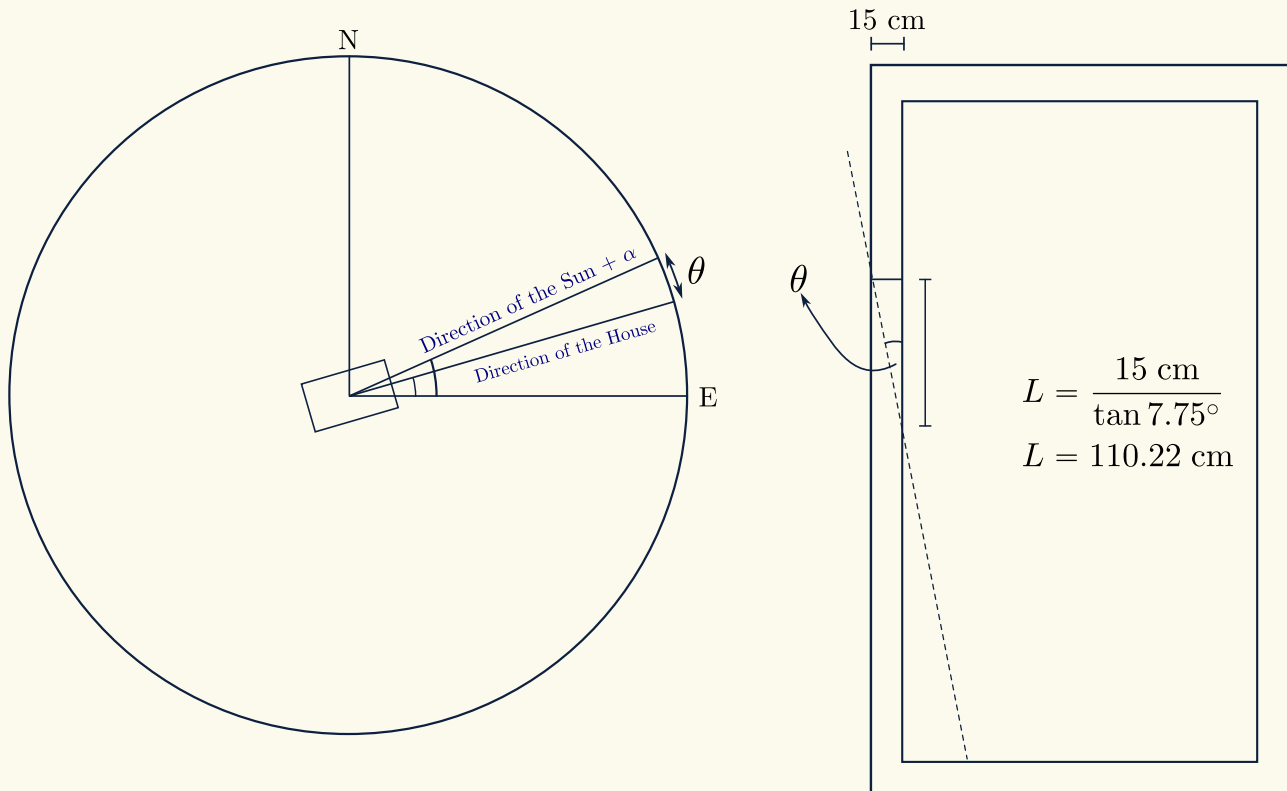

★ Solution of Day 17 ★

Check Problem Description: Day 17

Given:

1. Jet Width = 5° ,
2. Jet Axis of Rotation = 20° .

$$\theta_{in} = 20^\circ - \frac{5^\circ}{2} = 17.5^\circ$$

$$\Omega = 2\pi(1 - \cos \theta)$$

Question: What is the probability that we detect the pulsar?

$$\Omega_{out} = 2\pi(1 - \cos \theta_{out}) = 0.478 \text{ steradians}$$

$$\Omega_{in} = 2\pi(1 - \cos \theta_{in}) = 0.291 \text{ steradians}$$

$$\Omega_{jet} = 2(\Omega_{out} - \Omega_{in}) = 0.375 \text{ steradians}$$

Answer: Using spherical caps,

Let θ_{out} and θ_{in} be the two angles that define 2 distinct spherical caps.

The probability that we are in the area shined by the jets is as follows:

$$\theta_{out} = 20^\circ + \frac{5^\circ}{2} = 22.5^\circ$$

$$P = \frac{\Omega_{jet}}{4\pi} \times 100\% = \boxed{2.98\%}$$

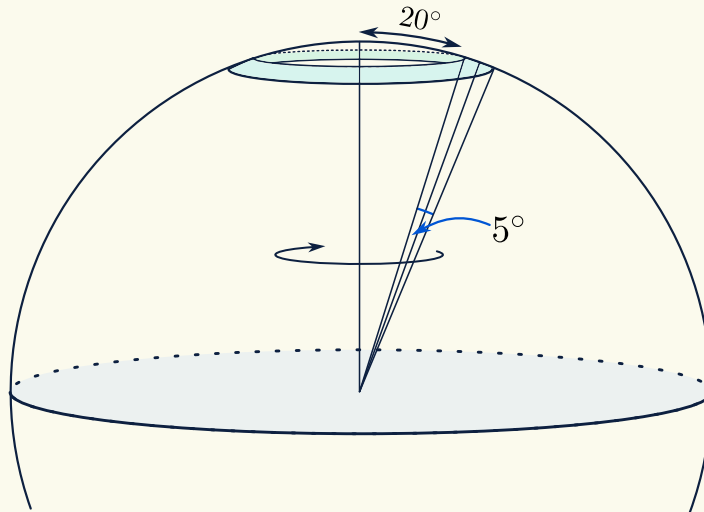

★ Solution of Day 18 ★

Check Problem Description: Day 18

Given:

1. Winter Solstice (Northern 21/22 Dec),
2. Greatest Elongation of Venus, it should be left of the Sun,
3. Ecliptic Latitude: $\beta_v = 0^\circ$.

Answer: From the relation of greatest elongation in triangle $\triangle SEV$:

$$\sin \varepsilon_v = SV$$

$$\sin \varepsilon_v = 0.72$$

$$\varepsilon_v = 46.05^\circ$$

Question: What is the equatorial coordinates (α_v, δ_v) of Venus?

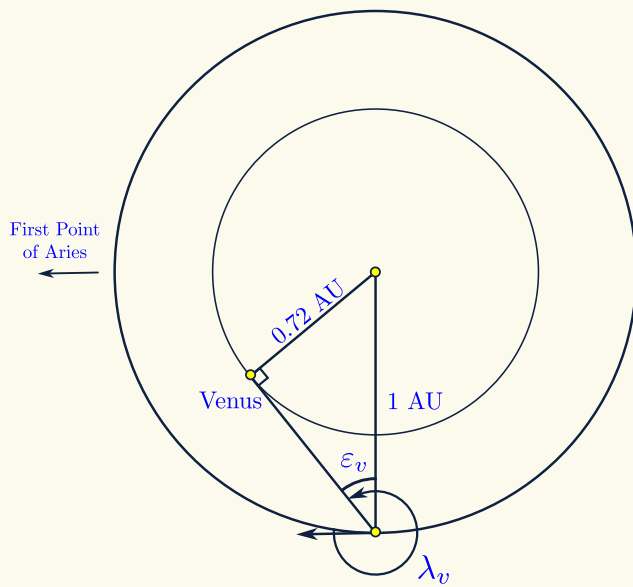

Now,

$$\begin{aligned}\lambda_v &= 270^\circ + \varepsilon_v \\ &= 316.05^\circ \\ \beta_v &= 0^\circ\end{aligned}$$

Since the β_v value is 0° , we can use the following coordinate transformation formulae:

$$\begin{aligned}\tan \alpha_v &= \cos \varepsilon \cdot \tan \lambda_v \\ \sin \delta_v &= \sin \varepsilon \sin \lambda_v\end{aligned}$$

Therefore, the equatorial coordinates for Venus are: $(21^h 14^m, -16^\circ 03')$.

★ Solution of Day 19 ★

Check Problem Description: Day 19

Given:

1. $R_0 = 4R_\odot$,
2. $M_0 = 6M_\odot$,
3. $B = 1 \times 10^{-4}$ T,
4. $R' = 16$ km.

Question: What is the magnetic field of star after it evolves into a Neutron star?

Answer: Using the conservation of magnetic flux, we're able to use

$$\begin{aligned}B_0 \cdot A_0 &= B' \cdot A' \\ (1 \times 10^{-4}) \cdot (4\pi R_0^2) &= B' \cdot (4\pi R'^2) \\ B' &= \left(\frac{R_0}{R'}\right)^2 \cdot (1 \times 10^{-4})\end{aligned}$$

$$\boxed{B' = 1.94 \times 10^6 \text{ T}}$$

★ Solution of Day 20 ★

Check Problem Description: Day 20

Given:

1. $T_0 = 2.73$ K,
2. $t = \frac{2}{3H_0} a^{\frac{3}{2}}$,
3. $H_0 = 70$ km/s/Mpc $= 2.26 \times 10^{-18}$ /s.

Question: What is the duration between $T = 0^\circ$ C and $T = 100^\circ$ C?

Answer:

$$\begin{aligned}0^\circ \text{ C} &= 273.15 \text{ K} \\ T &= T_0 \cdot a^{-1} \\ a &= \frac{T_0}{T}\end{aligned}$$

$$\begin{aligned}a_{0^\circ \text{ C}} &= \frac{T_0}{273.15 \text{ K}} \\ a_{0^\circ \text{ C}} &= 0.00999\dots\end{aligned}$$

Using the same method, we get:

$$\begin{aligned}a_{100^\circ \text{ C}} &= \frac{T_0}{273.15 \text{ K}} \\ a_{100^\circ \text{ C}} &= 0.00731\dots\end{aligned}$$

Now time interval,

$$\begin{aligned}\Delta t &= \frac{2}{3H_0} \left(a_{0^\circ \text{ C}}^{\frac{3}{2}} - a_{100^\circ \text{ C}}^{\frac{3}{2}} \right) \\ \Delta t &= 3.49 \text{ Myr}\end{aligned}$$

★ Solution of Day 21 ★

Check Problem Description: Day 21

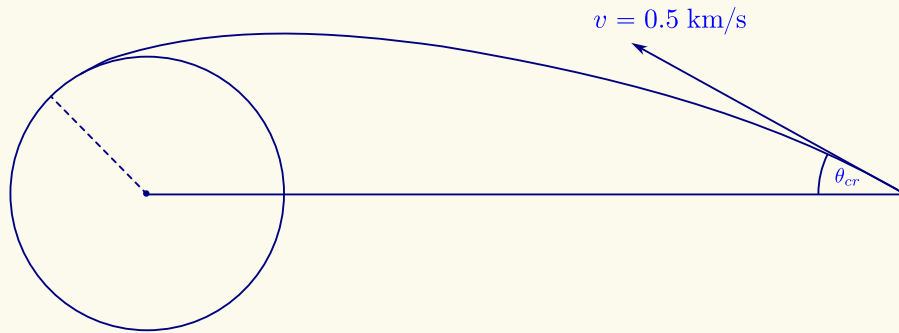

a. To determine whether a piece's orbit hits the Earth or not, we could check its' perigee distance.

iv. Conclusion

If $\theta < \theta_{cr}$ it will hit, in contrast, if $\theta > \theta_{cr}$, it won't hit.

If $r_{pe} < R_{\oplus} \implies$ The piece hits the Earth.

If $r_{pe} > R_{\oplus} \implies$ The piece does not hit the Earth.

Therefore, we could calculate θ_{cr} such that $r_{pe} = R_{\oplus}$.

i. Determine the semimajor axis (a)

$$\frac{1}{2}mv^2 - \frac{GMm}{r} = -\frac{GMm}{2a}$$

$$a = 388.766$$

ii. Determine the eccentricity (e)

$$r_{pe} = a(1 - e) = R_{\oplus}$$

$$e = 0.9836$$

iii. Determine θ_{cr} using angular momentum,

$$mvr \sin(180^\circ - \theta_{cr}) = m\sqrt{GMa(1 - e^2)}$$

$$\sin \theta_{cr} = \frac{\sqrt{GMa(1 - e^2)}}{vr}$$

$$\theta_{cr} = 13.13^\circ$$

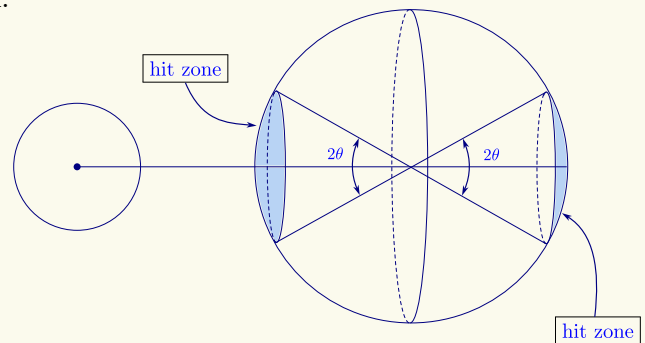

Therefore the fraction of the asteroid that will hit the Earth is

$$F = \frac{\Omega_{hit}}{\Omega_{total}} = \frac{2 \times 2\pi(1 - \cos \theta)}{4\pi} = 1 - \cos \theta$$

$$F = 2.61\%$$

b. If the pieces could hit points B and C, all the points on the Earth can be hit by pieces. Let the true anomaly at the initial conditions be f_0 , such that

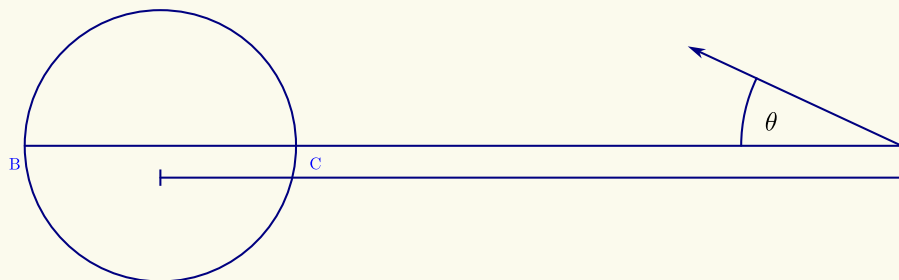

$$r_0 = \frac{a(1 - e^2)}{1 + e \cos f_0} \implies e \cos f_0 = \frac{a(1 - e^2)}{r_0} - 1$$

And at point B

$$e \cos f_0 = \frac{a}{r_0}(1 - e^2) - 1 = 1 - \frac{a}{R_\oplus}(1 - e^2)$$

$$1 - e^2 = \frac{2}{\frac{a}{r_0} + \frac{a^2}{R^2}}$$

$$e = 0.9856$$

Computing for θ

$$mvr_0 \sin \theta = m\sqrt{GMa(1 - e^2)}$$

$$\theta = 166.885^\circ$$

Therefore since point B can be hit, the entirety of the Earth's surface can be hit by the asteroid pieces.

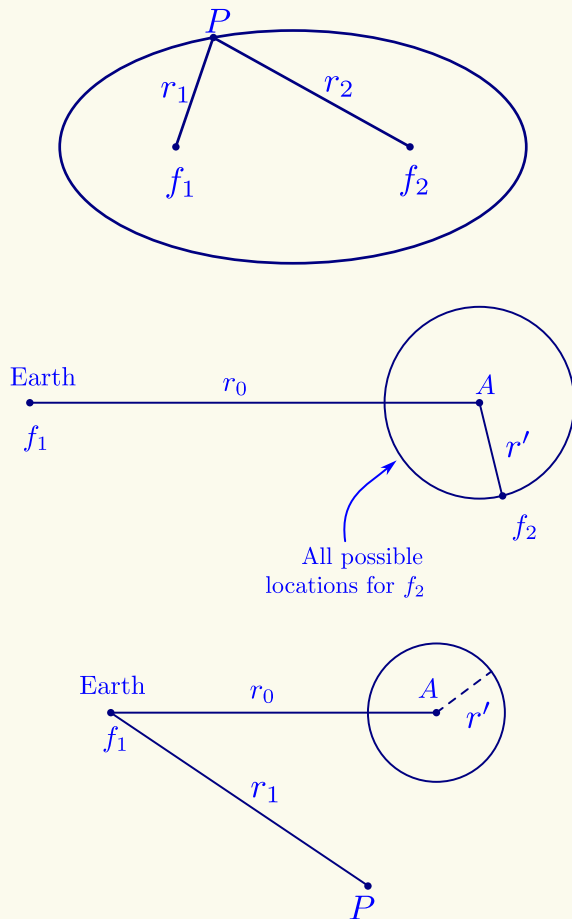

If we pick a random point P on the ellipse, its distance to f_1 which is r_1 , and to f_2 which is r_2 will

sum up to $2a$

$$r_1 + r_2 = 2a$$

We know that all of the pieces' orbits are ellipses with $a = 38876$ km, and one of its foci is at the Earth's center.

Using the previous property, we can determine all possible locations for the second focal point.

$$r_0 + r' = 2a$$

$$r' = 2a - r_0 = 152.553 \text{ km}$$

So f_2 can be anywhere as long as it is at distance r' from the asteroid, and each location of f_2 corresponds to a possible ellipse.

Now consider a random point P that is at distance r_1 from the Earth. From all of the possible ellipses before, we want to find the ellipse that is passing through the point P.

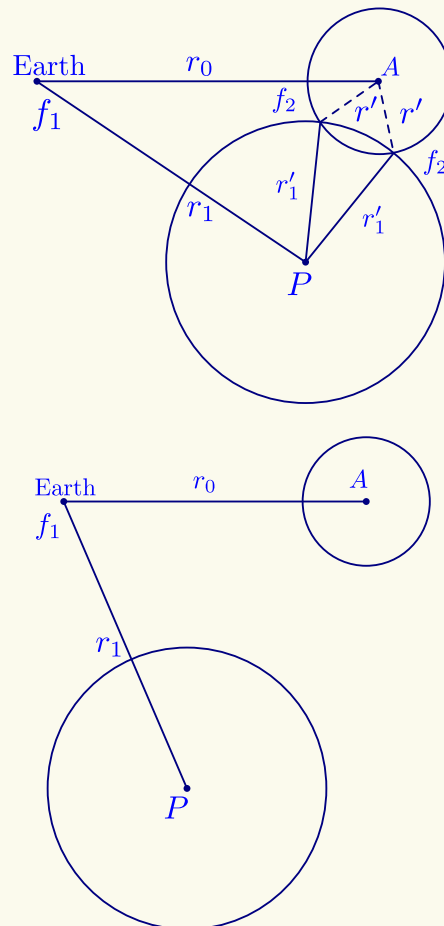

Point P is at the ellipse with semimajor $a = 388776$ km, so $r_1 + r'_1 = 2a \implies r'_1 = 2a - r_1$. So the second focus f_2 must be at distance r'_1 from point P.

From the previous sketch, there are two possible locations for the second focus, which means there are 2 possible orbits with $a = 388776$ km, passing through point A and point P.

If we pick a point P as such, there won't be any intersection points. This means out of all the possible ellipses, none pass through point P.

In other words, P is beyond the envelope.

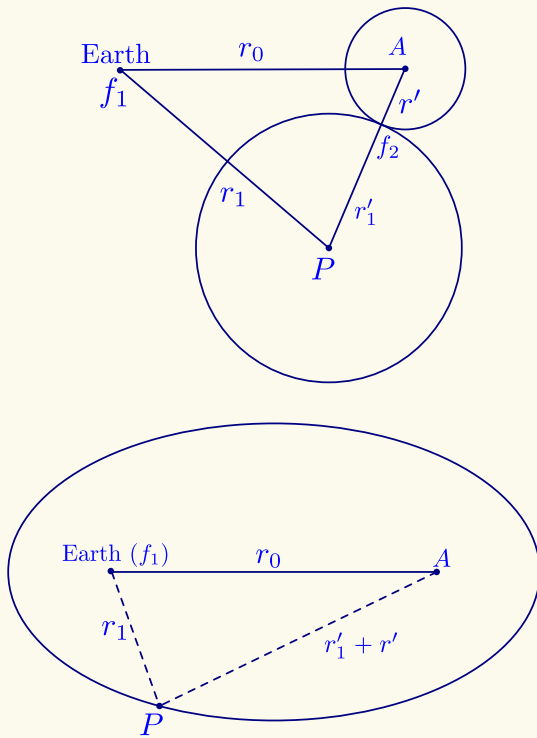

The crucial point is when the circles are tangent to one another, which means there is only one possible ellipse passing through point P. In this case, we can conclude that P is at the envelope.

$$\begin{aligned} r_0 + r' &= 2a \\ r_1 + r'_1 &= 2a \\ r_1 + r'_1 + r' &= 4a - r_0 \\ (r_1) + (r'_1 + r') &= 930.104 \text{ km} \end{aligned}$$

So the envelope is all sets of point P in which the distance of P to Earth (r_1) and P to the asteroid ($r'_1 + r'$) is a constant value.

Due to rotational symmetry, the envelope is then a spheroid with the Earth and the asteroid at its foci, and the size of the spheroid is

$$\begin{aligned} (r_1) + (r'_1 + r') &= 4a - r_0 = 2a' \\ a' &= 2a - \frac{1}{2}r_0 \\ a' &= 465.053 \text{ km} \end{aligned}$$

$$\begin{aligned} 2c &= 2a'e' = r_0 \\ e' &= \frac{r_0}{2a'} = \frac{r_0}{4a - r_0} \implies \boxed{e' = 0.672} \end{aligned}$$

★ Solution of Day 22 ★

Check Problem Description: Day 22

Given:

1. $e = 0.7$,
2. $T_{\max} = 250$ K,

Question: What is the minimum surface Temperature?

Answer: Notice that the minimum surface temperature is achievable only at aphelion.

$$L_{pe} = \frac{L_{\odot}}{4\pi[a(1-e)]^2}$$

$$L_{ap} = \frac{L_{\odot}}{4\pi[a(1+e)]^2}$$

Using the formula for planets 'Luminosity', we can also apply the same formula for this asteroid. Notice that the albedo is 1 due to the asteroid being a black body.

$$E \cdot \cancel{A} \cdot \cancel{\pi R_{ast}^2} = 4\pi \cancel{R_{ast}^2} \sigma T_{ast}^4$$

$$T_{ast} = \sqrt[4]{\frac{E}{4\sigma}}$$

$$T_{ast} = \sqrt[4]{\frac{L}{4\pi d^2}} \Rightarrow \sqrt[4]{\frac{L_{\odot}}{16\pi\sigma d^2}}$$

Therefore we can determine the minimum temperature:

$$\frac{T_{\max}}{T_{\min}} = \frac{\sqrt[4]{\frac{L_{\odot}}{16\pi\sigma[a(1+e)]^2}}}{\sqrt[4]{\frac{L_{\odot}}{16\pi\sigma[a(1+e)]^2}}}$$

$$\frac{T_{\max}}{T_{\min}} = \sqrt[4]{\frac{(1+e)^2}{(1-e)^2}} \Rightarrow 2.38$$

$$T_{\min} = \frac{T_{\max}}{2.38} = \boxed{105.02 \text{ K}}$$

★ Solution of Day 23 ★

Check Problem Description: Day 23

Given:

1. $M = 2.31^m$,
2. $d = 1.5$ kpc,
3. $m = 14.59^m$,
4. $D = 0.3 \mu m$.

Question: What is the dust particles' average density in the observation direction?

Answer: Calculate the amount of absorption,

$$m - M = -5 + 5 \log d + A$$

$$A = 1.4$$

Optical Depth (τ),

$$A = 2.5 \log e \cdot \tau \approx 1.086\tau$$

$$\tau = 1.29$$

Again for dust particles, we can write,

$$\tau = \sigma n d$$

neglecting the scattering effects, we can approximate the extinction cross-section (σ) equal to the geometric cross-section:

$$\tau = \left(\frac{1}{4}\pi D^2\right) n d$$

$$n = \frac{\tau}{\frac{1}{4}(\pi D^2) d}$$

$$n = \boxed{3.93 \times 10^{-7} / \text{m}^3}$$

★ Solution of Day 24 ★

Check Problem Description: Day 24

$$\begin{aligned} \sin \alpha &= \frac{v}{c} \sin \theta' \\ \theta' &= \theta - \alpha \\ \theta' &= 90^\circ - \alpha \\ \sin \alpha &= \frac{v}{c} \sin(90^\circ - \alpha) \\ \tan \alpha &= \frac{v}{c} \\ \alpha &= 20.52'' \\ \lambda'_\odot &= \lambda_\odot - \alpha \\ \lambda'_\odot &= 89^\circ 59' 39.48'' \end{aligned}$$

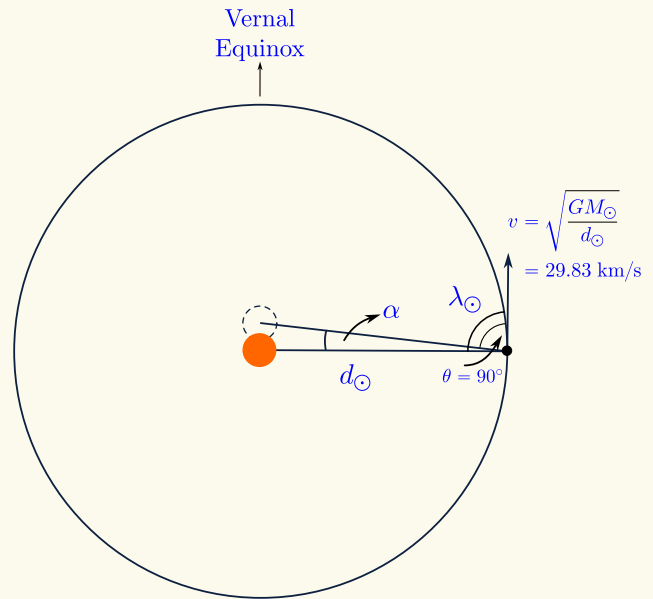

★ Solution of Day 25 ★

Check Problem Description: Day 25

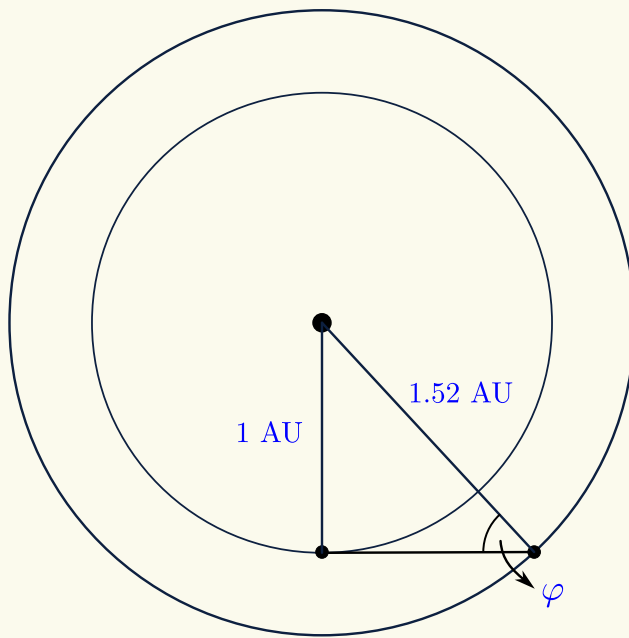

The phase equation is given by,

$$f = \frac{1 + \cos \varphi}{2}$$

To have the minimum value of f , the value of φ has to be maximized. Consider an observer on the surface of Mars, the angle φ would be the elongation angle. Now, notice that the maximum value of φ would only be achievable by having Earth on Mars' greatest elongation angle, which would require the Mars – Earth – Sun angle to be exactly 90° , or to have the line of sight of Mars – Earth be tangential to Earth's Orbit.

Therefore,

$$\begin{aligned} \sin \varphi &= \frac{1}{1.52} \implies \varphi = 41.14^\circ \\ f &= 87.66\% \end{aligned}$$

★ Solution of Day 26 ★

Check Problem Description: Day 26

Given:

- Observed wavelength of $\lambda_{H\alpha} = 7500 \text{ \AA}$,

Question: What is the radial velocity v_r ?

Using Rydberg formula for Hydrogen,

$$\frac{1}{\lambda_0} = R \left(\frac{1}{n^2} - \frac{1}{m^2} \right) \implies \lambda_0 = 6564.67 \text{ \AA}$$

$$z = \frac{\lambda - \lambda_0}{\lambda} = 0.142$$

Answer: Due to the high values of Doppler Shifting, we have to use the relativistic Doppler Shift formula:

$$z = \frac{\Delta\lambda}{\lambda_0} = \sqrt{\frac{1 + \frac{v_r}{c}}{1 - \frac{v_r}{c}}} - 1$$

Solving for v_r :

$$z + 1 = \sqrt{\frac{1 + \frac{v_r}{c}}{1 - \frac{v_r}{c}}}$$

$$(z + 1)^2 = \frac{1 + \frac{v_r}{c}}{1 - \frac{v_r}{c}}$$

$$(z + 1)^2 \left(1 - \frac{v_r}{c} \right) = 1 + \frac{v_r}{c}$$

$$(z + 1)^2 - (z + 1)^2 \frac{v_r}{c} = 1 + \frac{v_r}{c}$$

$$(z + 1)^2 - 1 = \frac{(z + 1)^2}{c} v_r + \frac{v_r}{c}$$

$$(z + 1)^2 - 1 = \left((z + 1)^2 + 1 \right) \frac{v_r}{c}$$

$$v_r = \left(\frac{(z + 1)^2 - 1}{(z + 1)^2 + 1} \right) c$$

$v_r = 0.132c$

★ Solution of Day 27 ★

Check Problem Description: Day 27

Given: Since the Sun's altitude determines when it is visible, we define the sunset duration as the time taken for the Sun to move from an altitude of

$$a_{\odot,1} = \frac{\theta_{\odot}}{2}, \quad a_{\odot,2} = -\frac{\theta_{\odot}}{2}$$

Notice that, for an observer on the North Pole the Sun's altitude is equal to its declination, $a_{\star} = \delta_{\star}$. Therefore, we can conclude that the sunset at the North Pole occurs when the Sun's altitude is between $\frac{\theta_{\odot}}{2}$ and $-\frac{\theta_{\odot}}{2}$.

Derived from the *Ecliptic-Equatorial* spherical triangle, for any stellar object that lies on the ecliptic plane ($\beta = 0$), follow the form:

$$\sin \delta = \sin \varepsilon \sin \lambda$$

Therefore we can perform the calculations to find $\Delta\lambda$, which will lead into finding Δt

- $\sin \delta_{\odot,1} = \sin \varepsilon \sin \lambda_{\odot,1}$
 $\delta_{\odot,1} = 0.266^\circ$
 $\lambda_{\odot,1} = 179^\circ 19' 59.77''$
- $\sin \delta_{\odot,2} = \sin \varepsilon \sin \lambda_{\odot,2}$
 $\delta_{\odot,2} = -0.266^\circ$
 $\lambda_{\odot,2} = 180^\circ 40' 0.83''$

The difference in ecliptic longitude between these two positions is:

$$\Delta\lambda_{\odot} = 1^\circ 20' 0.45''$$

To convert this longitude change into time,

$$\lambda = \frac{n}{365.25} \times 360^\circ$$

$$n = \frac{\lambda}{360^\circ} \times 365.25$$

$$\Delta t = \frac{\Delta\lambda}{360^\circ} \times 365.25$$

$\Delta t = 32^h 28^m 11^s$

★ Solution of Day 28 ★

Check Problem Description: Day 28

Given:

1. 7 October,
2. $(\lambda_A, \beta_A) = (30^\circ, 0^\circ)$,
3. $\theta = 0.275''$,
4. $\Delta\lambda = 90''$ (to the West).
5. $\Delta t_1 = 3^h$
6. $f_0 = 100$ MHz
7. $f' = 99.9963$ MHz
8. $m_A = 10.52$

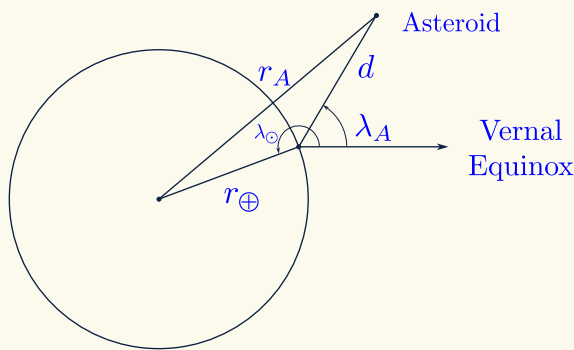

a)

$$7 \text{ Oct} \implies \lambda_{\odot} = \frac{n}{T} \times 360^\circ = 194.78^\circ$$

$$d = \frac{1}{2}c \cdot \Delta t_2 = 1.26 \text{ AU}$$

$$r_A^2 = r_{\oplus}^2 + d^2 - 2 \cdot r_{\oplus} \cdot d \cdot \cos(\lambda_{\odot} - \lambda_A)$$

$$r_A = \boxed{2.24 \text{ AU}}$$

b) First we calculate its velocity relative to the Earth

- Radial velocity

$$z = \frac{\lambda - \lambda_0}{\lambda_0} = \frac{f_0 - f}{f} = \frac{2v_r}{c}$$

$$v_r = \frac{f_0 - f}{2f} = c$$

$$v_r = 5.55 \text{ km/s}$$

- Tangential velocity

$$v_t = \omega d = \left(\frac{\Delta\lambda}{\Delta t_1} \right) d$$

$$v_t = 7.64 \text{ km/s}$$

Heliocentric Velocity (v_A)

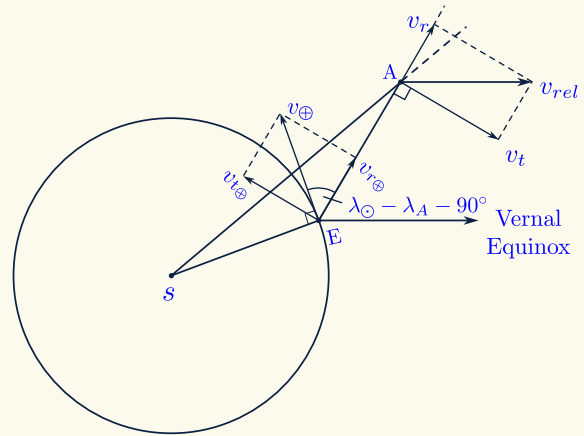

$$v_{\oplus} = \sqrt{\frac{GM}{r_{\oplus}}}$$

$$v_{r_{\oplus}} = v_{\oplus} \cos(\lambda_{\oplus} - \lambda_A - 90^\circ) = 7.82 \text{ km/s}$$

$$v_{t_{\oplus}} = v_{\oplus} \sin(\lambda_{\oplus} - \lambda_A - 90^\circ) = 28.74 \text{ km/s}$$

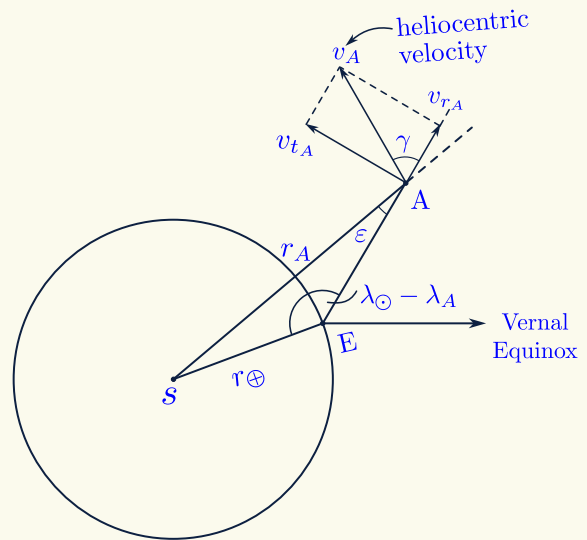

$$\vec{v}_A = \vec{v}_{rel} + \vec{v}_{\oplus}$$

$$v_{r_A} = v_{\oplus} + v_{r_{\oplus}} = 13.37 \text{ km/s}$$

$$v_{t_A} = -v_t + v_{t_{\oplus}} = 21.1 \text{ km/s}$$

$$v_A = \sqrt{v_{r_A}^2 + v_{t_A}^2} = \boxed{24.98 \text{ km/s}}$$

c) Calculate γ and ε

$$\tan \gamma = \frac{v_{tA}}{v_{rA}} \implies \gamma = 57.65^\circ$$

$$\frac{\sin \varepsilon}{r_\oplus} = \frac{\sin(\lambda_\odot - \lambda_A)}{r_A} \implies \varepsilon = 6.72^\circ$$

Calculate semi-major axis (a)

$$\frac{1}{2}mv_A^2 - \frac{GMm}{r_A} \equiv -\frac{GMm}{2a}$$

$$a = 5.32 \text{ AU}$$

Calculate eccentricity (e)

$$mv_A r_A \sin(\gamma + \varepsilon) = m\sqrt{GMa(1 - e^2)}$$

$$e = 0.6776$$

d) Radius of the Asteroid

$$\theta = \frac{2R}{d} \implies R = \frac{1}{2}\theta d$$

$$R = 125.99 \text{ km}$$

Flux of the asteroid,

$$m_A - m_\odot = -2.5 \log \left(\frac{E_A}{E_\odot} \right)$$

$$E_A = 1.62 \times 10^{-12} \text{ W/m}^2$$

Albedo of the asteroid (α)

$$E_A = \left(\frac{L_\odot}{4\pi r_A^2} \pi R^2 \alpha \right) \frac{1}{4\pi d^2}$$

$$\alpha = 0.0528$$

e) Perihelion distance

$$r_{pe} = a(1 - e) = 1.72 \text{ AU}$$

Using thermal Equilibrium

$$E_{\text{absorb}} = E_{\text{emit}}$$

$$\frac{L_\odot}{4\pi r_{pe}^2} \pi R^2 (1 - \alpha) = 4\pi R^2 \sigma T^4$$

$$T = \left(\frac{L_\odot (1 - \alpha)}{16\pi \sigma r_{pe}^2} \right)^{\frac{1}{4}}$$

$$T = 210.59 \text{ K}$$

★ Solution of Day 29 ★

Check Problem Description: Day 29

Given:

1. $r_{orb} = 10 \text{ kpc}$,
2. $v_{orb} = 300 \text{ km/s}$,
3. $L_G = 4 \times 10^{10} L_\odot$.

$$M_G = 2.09 \times 10^{11} M_\odot$$

Now,

Question: What is the mass-to-light ratio of the galaxy? **Answer:**

$$v_{orb} = \sqrt{\frac{GM_G}{r_{orb}}} \implies M_G = \frac{v_{orb}^2 \cdot r_{orb}}{G}$$

$$\Upsilon = M/L = \frac{M_G}{L_G} = \frac{2.09 \times 10^{11} M_\odot}{4 \times 10^{10} L_\odot}$$

$$\Upsilon = 5.22$$

Note. Masses are often calculated from the dynamics of the virialized system or from gravitational lensing. The original author simplified by using orbital velocity. Typical mass-to-light ratios for galaxies range from 2 to $10 \Upsilon_\odot$ while on the largest scales, the mass-to-light ratio of the observable universe is approximately $100 \Upsilon_\odot$, in concordance with the current best fit cosmological model.

★ Solution of Day 30 ★

Check Problem Description: Day 30

Given:

1. $\delta_{GRS} = 1.5' = 90''$,
2. $f/D = 18 \text{ km/s}$,
3. $D = 60 \text{ cm} = 600 \text{ mm}$.

Question: What is the size of the image on the plate?

Answer: What we're trying to determine is the length of the projected image out of the telescope. therefore, we need the plate scale parameter of the telescope.

We know the mathematical expression for the plate

scale is as follows

$$PS = \frac{206265''}{f} = \dots \text{ ''/mm}$$

knowing that we need to determine the f value of the telescope.

$$f/D = 18 \implies f = 18 \cdot D = 10800 \text{ mm}$$

$$PS = \frac{206265''}{f} = 19.1''/\text{mm}$$

Dividing the δ_{GRS} by PS , we get the projected image length,

$$l = \frac{\delta_{GRS}}{PS} = \boxed{4.71 \text{ mm}}$$

★ Solution of Day 31 ★

Check Problem Description: Day 31

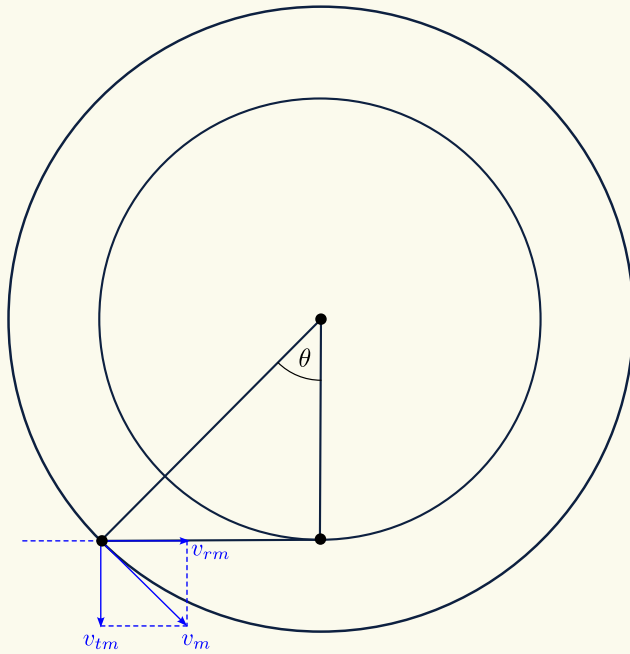

Note. To understand the problem statement one need to understand the name of each planetary position and especially notice if is it an Eastern or

Western position (Elongation/Quadrature). Also one should understand the significance of the First Point of Aries. Here it means that it lies on the ecliptic plane $\beta = 0$, so we don't want to account for additional components of the velocity.

Because the value of Δt is very short, we're allowed to use the approximation using the relative angular velocity.

$$v_m = \sqrt{\frac{GM_{\odot}}{d_m}} = 24.2 \text{ km/s}$$

$$r_m = 1.52 \text{ AU}$$

$$v_{tm} = v_m \cdot \sin \theta$$

$$d_{m-\oplus} = r_m \cdot \sin \theta$$

$$\omega_m = \frac{v_{tm}}{d_{m-\oplus}} = \frac{v_m}{r_m} = 0.525^\circ/\text{day}$$

Therefore the next day we would see Mars 31'31.21'' off the vernal equinox.

★ Solution of Day 32 ★

Check Problem Description: Day 32

Given:

1. $v_{orb} = 220 \text{ km/s}$,
2. $d_G = 8 \text{ kpc}$,
3. $y_G = 0.5 \text{ kpc} \implies \text{disk thickness}$.
4. $n = 0.495 \text{ star/pc}^3$

Question: What is the value of R_s ?**Answer:**

- Calculating the mass inside the Sun's orbit

$$v_{orb} = \sqrt{\frac{GM_0}{d_G}}$$

$$M_0 = \frac{v_{orb}^2 \cdot d_G}{G} \implies M_0 = 8.98 \times 10^{10} M_\odot$$

- Calculating the predicted mass inside the Sun's orbit

$$M_{0,pred} = \pi d_G^2 y_G n$$

$$M_{0,pred} = 4.98 \times 10^{10} M_\odot$$

- difference in mass is the mass of the Black-hole

$$M_{BH} = M_0 - M_{0,pred} = 4 \times 10^{10} M_\odot$$

- Calculating the Schwarzschild Radius

$$R_s = \frac{2GM_{BH}}{c^2} = 1.19 \times 10^{14} \text{ m} = \boxed{791.86 \text{ AU}}$$

★ Solution of Day 33 ★

Check Problem Description: Day 33

Given:

1. $d = 40 \text{ mm}$,
2. $d_{\text{telescope}} = 1620 \text{ mm}$,
3. $d_{\text{exit}} = d_{\text{pupil}} = 5 \text{ mm}$.
4. Pixel size = $9\mu\text{m} \times 9\mu\text{m}$

Question: How many pixels are activated?**Answer:**

- Calculating the focal length

$$d_{\text{exit}} = \frac{D}{M} \implies M = \frac{D}{d_{\text{exit}}}$$

$$\frac{f_{OB}}{f_{OC}} = M = \frac{400}{5}$$

$$f_{OB} = 80 \cdot f_{OC} \quad (1)$$

- Given:

$$d_{\text{telescope}} = 1620$$

$$f_{OB} + f_{OC} = 1620 \quad (2)$$

Eq. 1 \rightarrow 2

$$81 \cdot f_{OC} = 1620 \text{ mm}$$

$$f_{OC} = 20 \text{ mm}$$

$$f_{OB} = 1600 \text{ mm}$$

- Calculating the plate scale,

$$PS = \frac{206265''}{f_{OB}} = 128.92''/\text{mm}$$

- Calculating the Sun's projected length,

$$\delta_\odot = \frac{2 \times 6.69 \times 10^8 \text{ mm}}{1.5 \times 10^{11} \text{ m}} \times 206265$$

$$\delta_\odot = 1914.144''$$

$$l = \frac{\delta_\odot}{PS} = 14.848 \text{ mm}$$

- Amount of pixels activated,

$$\left(\frac{l}{\text{px. size}} \right)^2 \approx \boxed{2722500 \text{ px}}$$

★ Solution of Day 34 ★

Check Problem Description: Day 34

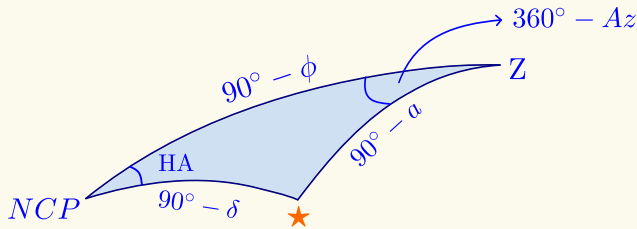

Also, notice that the Altitude of the Sun (a_{\odot}) and the Azimuth of the Sun (Az_{\odot}) affect both the direction AND the length of the shadow.

Given:

1. $\phi = 34^{\circ}43'23''$,
2. 19 October,
3. Observation: 1 Hour before Sunset
4. $h = 52$ m.
5. $\varepsilon = 23.5^{\circ}$

$$\lambda_{\odot} = \frac{n}{365.25} \times 360^{\circ}$$

$$\lambda_{\odot} = \frac{212}{365.25} \times 360^{\circ} \implies \lambda_{\odot} = 208^{\circ}57'9.98''$$

$$\sin \delta_{\odot} = \sin \varepsilon \sin \lambda_{\odot} \implies \delta_{\odot} = -11^{\circ}7'46.76''$$

For $a = 0^{\circ}$ the following equation is applicable,

$$\begin{aligned} \cos HA &= -\tan \phi \tan \delta \\ \cos HA_{\odot} &= -\tan \phi \tan \delta_{\odot} \\ \implies HA_{\odot} &= 5^h 16^m 37.23^s \end{aligned}$$

Therefore 1 hour before sunset would be $4^h 16^m 37.23^s$.

$$\begin{aligned} \sin a_{\odot} &= \sin \phi \sin \delta_{\odot} + \cos \phi \cos \delta_{\odot} \cos HA_{\odot} \\ a_{\odot} &= 10^{\circ}7'10.68'' \end{aligned}$$

$$\begin{aligned} \sin \delta_{\odot} &= \sin a_{\odot} \sin \phi + \cos a_{\odot} \cos \phi \cos(360^{\circ} - Az) \\ \cos(360^{\circ} - Az) &= \frac{\sin \delta_{\odot} - \sin a_{\odot} \sin \phi}{\cos a_{\odot} \cos \phi} \\ \implies Az &= 243^{\circ}46'2.33'' \end{aligned}$$

Let AB be the tower, with tipping angle θ , and height H , then its shadow would be AD. Notice that B's shadow is D.

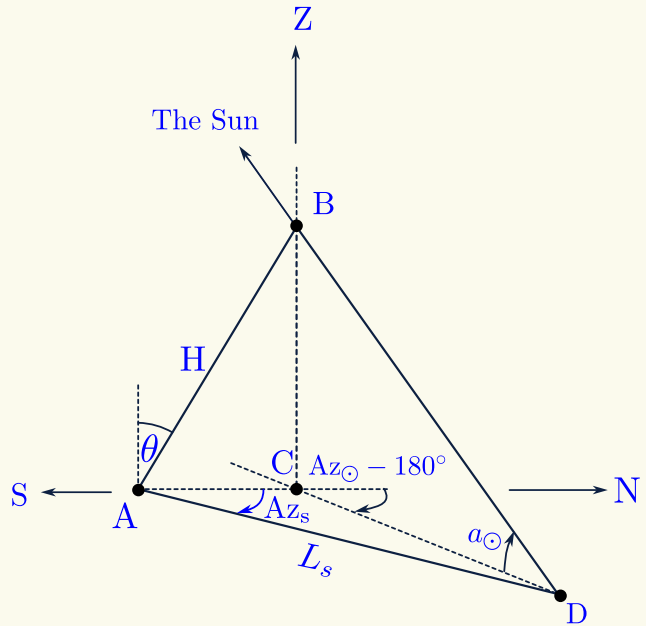

To determine L_s we can do the following

- Determine AC

$$\begin{aligned} AC &= H \sin \theta \\ AC &= 4.98 \text{ m} \end{aligned}$$

- Determine CB

$$\begin{aligned} CB &= H \cos \theta \\ AC &= 51.76 \text{ m} \end{aligned}$$

- Determine CD

$$\begin{aligned} CD &= \frac{CB}{\tan a_{\odot}} \\ CD &= 290 \text{ m} \end{aligned}$$

- Determine $\angle ACD$

$$\begin{aligned} \angle ACD &= 180^{\circ} - (Az_{\odot} - 180^{\circ}) \\ \angle ACD &= 360^{\circ} - Az_{\odot} = 116^{\circ}13'57.67' \end{aligned}$$

$$L_s = \sqrt{AC^2 + CD^2 - 2 \cdot AC \cdot CD \cdot \cos(\angle ACD)}$$

$$L_s = 292.24 \text{ m}$$

To determine Az_s , we can do the following:

$$\frac{L_s}{\sin(\angle ACD)} = \frac{CD}{\sin(Az_s)}$$

$$\sin(Az_s) = \frac{CD}{L_s} \cdot \sin(\angle ACD)$$

$$Az_s = 62^\circ 53' 26.83''$$

Therefore the final answers are

$$L_s = 292.24 \text{ m,}$$

$$Az_s = 62^\circ 53' 26.83''.$$

★ Solution of Day 35 ★

Check Problem Description: Day 35

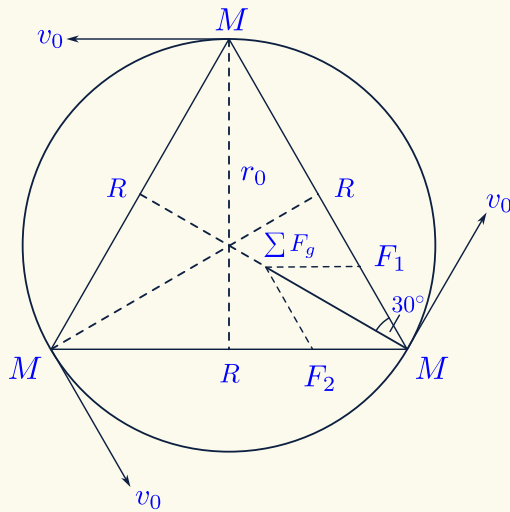

- a) • Gravitational Force

$$F_1 = F_2 = \frac{GM^2}{R^2}$$

$$\sum F_g = 2 \cdot F_1 \cdot \cos 30^\circ$$

$$\sum F_g = \sqrt{3} \frac{GM^2}{R^2}$$

- Orbital Velocity

$$\sum F_g = F_c$$

$$\sqrt{3} \frac{GM^2}{R^2} = \frac{Mv_0^2}{\frac{1}{\sqrt{3}}R^2}$$

$$v = \sqrt{\frac{GM}{R}}$$

- Distance to the barycenter

$$r_0 = \frac{\frac{R}{2}}{\cos 30^\circ}$$

$$r_0 = \frac{1}{\sqrt{3}}R$$

- Orbital Period

$$T = \frac{2\pi r_0}{v_0}$$

$$T = 2\pi \frac{1}{\sqrt{3}}R \sqrt{\frac{R}{GM}}$$

$$T = \sqrt{\frac{4\pi^2 R^3}{3GM}}$$

- b) Compute M' that will induce the same gravitational acceleration as the original problem

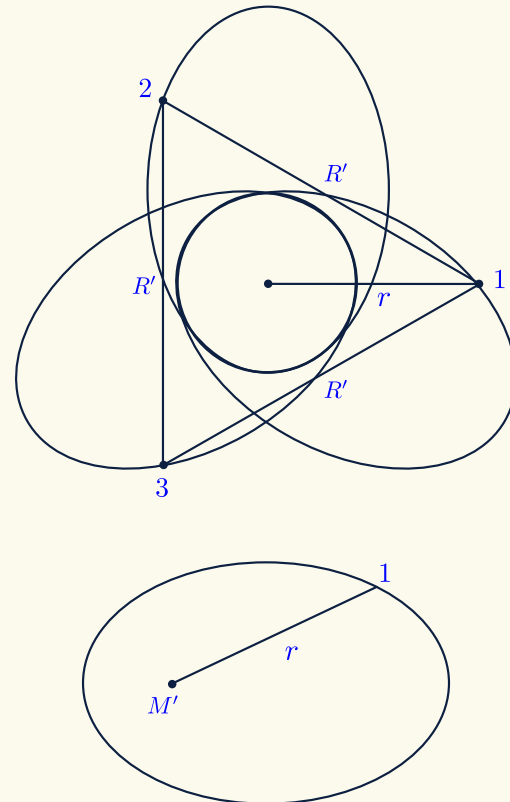

At any random position, the total gravitational acceleration of Star 1 is

$$a_g = \frac{\sqrt{3}GM}{R'^2}$$

To analyze the orbit of Star 1, we can make the one-body equivalence of its orbit.

$$\begin{aligned} \frac{GM'}{r^2} &= \frac{\sqrt{3}GM}{R'^2} \\ M' &= \sqrt{3} \frac{r^2}{R'^2} M = \sqrt{3} \frac{\frac{1}{3}r^2}{R'^2} M = \sqrt{3} \frac{\frac{1}{3}R'^2}{R'^2} M \\ M' &= \frac{1}{\sqrt{3}} M \end{aligned}$$

c) Now we can analyze its orbit as one body problem with central mass M' , apoapsis distance r_0 and its velocity at apoapsis is $\frac{v_0}{2}$

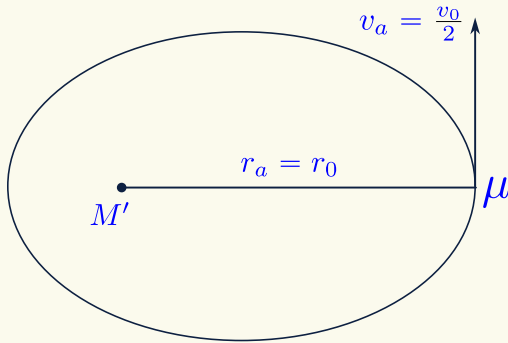

• Semimajor axis (a)

$$\frac{1}{2}\mu v_a^2 - \frac{GM'\mu}{r_a} = -\frac{GM'\mu}{2a}$$

$$a = \left(\frac{2}{r_a} - \frac{v_a^2}{GM'} \right)^{-1}$$

$$a = \left(\frac{2}{\frac{1}{\sqrt{3}R}} - \frac{\frac{1}{4} \frac{GM}{R}}{G \frac{1}{\sqrt{3}} M'} \right)^{-1}$$

$$a = \left(\frac{2\sqrt{3}}{R} - \frac{\sqrt{3}}{4R} \right)^{-1}$$

$$a = \frac{4\sqrt{3}}{21} R$$

• Period (T)

$$\frac{T^2}{a^3} = \frac{4\pi^2}{GM}$$

$$T = \sqrt{\frac{4\pi^2 \left(\frac{4\sqrt{3}}{21} R \right)^3}{G \left(\frac{1}{\sqrt{3}} M \right)}}$$

$$T = \sqrt{\frac{4^4 \pi^2 3^2 R^3}{21^3 GM}}$$

$$T = \sqrt{\frac{256\pi^2 R^3}{1029 GM}}$$

• Eccentricity (e)

$$r_a = a(1 + e)$$

$$e = \frac{r_a}{a} - 1$$

$$e = \frac{\frac{1}{\sqrt{3}}}{\frac{4\sqrt{3}}{21}} - 1$$

$$e = 0.75$$

★ Solution of Day 36 ★

Check Problem Description: Day 36

Given:

1. Flat Universe,
2. $H_0 = 70$ km/s/Mpc,

Question: What is the Energy density?

Answer: Since the universe is Flat, the energy density is the

critical energy density (ε_c).

$$E = mc^2 \implies \frac{E}{V} = \frac{mc^2}{V}$$

$$\varepsilon = \rho c^2 \implies \varepsilon_c = \rho_c c^2$$

• Solving for ρ_c

$$\rho = \frac{3H_0^2}{8\pi G} = 9.16 \times 10^{-27} \text{ kg/m}^3$$

• Solving for ε_c

$$\varepsilon_c = \rho_c c^2$$

$$\varepsilon_c = 8.23 \times 10^{-10} \text{ Jm}^{-3}$$

★ Solution of Day 37 ★

Check Problem Description: Day 37

Given:

1. $T_1 = 2$ years
2. $T_2 = 5$ years

Question: Δt

Answer: Let $\frac{GM}{4\pi^2}$ be a constant k , and a_1, a_2 be the orbital radii for the first and second orbits, respectively.

$$\frac{T_1^2}{a_1^3} = \frac{1}{k} \Rightarrow a_1^3 = T_1^2 \cdot k \Rightarrow a_1 = \sqrt[3]{T_1^2 \cdot k} \quad (1)$$

$$\frac{T_2^2}{a_2^3} = \frac{1}{k} \Rightarrow a_2^3 = T_2^2 \cdot k \Rightarrow a_2 = \sqrt[3]{T_2^2 \cdot k} \quad (2)$$

$$(1) + (2)$$

$$a_1 + a_2 = \sqrt[3]{k} \left(\sqrt[3]{T_1^2} + \sqrt[3]{T_2^2} \right) \quad (3)$$

$$a_H = \frac{a_1 + a_2}{2}$$

Therefore we can calculate the duration of the transfer (which is exactly half of the period of the

Hohmann orbit by doing the following:

$$\begin{aligned} \frac{T_H^2}{a_H^3} &= \frac{1}{k} \Rightarrow \frac{(2\Delta t)^2}{\left(\frac{a_1+a_2}{2}\right)^3} = \frac{1}{k} \\ &\Rightarrow \frac{a_1 + a_2}{\sqrt[3]{32} \cdot (\Delta t)^{\frac{2}{3}}} = \sqrt[3]{k} \end{aligned}$$

Inserting (3) into the equation:

$$\begin{aligned} \frac{\sqrt[3]{k} \left(\sqrt[3]{T_1^2} + \sqrt[3]{T_2^2} \right)}{\sqrt[3]{32} \cdot (\Delta t)^{\frac{2}{3}}} &= \sqrt[3]{k} \\ (\Delta t)^{\frac{2}{3}} &= \frac{\left(\sqrt[3]{T_1^2} + \sqrt[3]{T_2^2} \right)}{\sqrt[3]{32}} \\ \Delta t &= \left(\sqrt[3]{T_1^2} + \sqrt[3]{T_2^2} \right)^{3/2} \cdot \left(2^{-\frac{5}{3}} \right)^{\frac{3}{2}} \\ \Delta t &= \left(\sqrt[3]{T_1^2} + \sqrt[3]{T_2^2} \right)^{3/2} \cdot \left(2^{-\frac{5}{2}} \right) \end{aligned}$$

Inserting T_1 and T_2 into the equation:

$$\Delta t = 1.69 \text{ years}$$

★ Solution of Day 38 ★

Check Problem Description: Day 38

Given:

1. $T_{\text{orb}} = 36.05$ year,
2. $r_{\text{orb}} = 100$ AU,

Question: What is the blackhole's density?**Answer:**

$$\begin{aligned} \frac{T_{\text{orb}}^2}{r_{\text{orb}}^3} &= \frac{4\pi^2}{GM_{\star}} \\ M_{\star} &= \frac{4\pi^2 r_{\text{orb}}^3}{T_{\text{orb}}^2 G} \Rightarrow M_{\star} = 771.28 M_{\odot} \\ R_s &= \frac{2GM_{\star}}{c^2} = 2290.89 \text{ km} \\ \rho_{\text{BH}} &= \frac{M_{\star}}{\frac{4}{3}\pi R_s^3} = \boxed{3.0 \times 10^{13} \text{ kg/m}^3} \end{aligned}$$

★ Solution of Day 39 ★

Check Problem Description: Day 39

Given:

- $\delta_{\max} = 6''$,
- $\delta_{\min} = 1.5''$.

Question: What is its orbital eccentricity?**Answer:**

$$e = \frac{c}{a}$$

Notice that c and a could be written in terms of r_{pe} and r_{ap}

$$c = \frac{r_{ap} - r_{pe}}{2} \quad (1)$$

$$a = \frac{r_{ap} + r_{pe}}{2} \quad (2)$$

Therefore,

$$e = \frac{r_{ap} - r_{pe}}{r_{ap} + r_{pe}} \quad (3)$$

Notice that r_{pe} and r_{ap} can be written in terms of δ_{\max} and δ_{\min}

$$r_{pe} = \delta_{\min} \cdot d$$

$$r_{ap} = \delta_{\max} \cdot d$$

Therefore, we are able to write the 3rd equation as:

$$\begin{aligned} e &= \frac{\delta_{\max} \cdot d - \delta_{\min} \cdot d}{\delta_{\max} \cdot d + \delta_{\min} \cdot d} \\ &= \frac{\delta_{\max} - \delta_{\min}}{\delta_{\max} + \delta_{\min}} \\ &\Rightarrow e = \frac{6'' - 1.5''}{6'' + 1.5''} \\ &\quad \boxed{e = 0.6} \end{aligned}$$

★ Solution of Day 40 ★

Check Problem Description: Day 40

Given:

- $a = 1.6$ AU,
- $e = 0.57$ AU,
- It is an asteroid.

Question: What is the velocity of the asteroid 30% into its' revolution?**Answer:** Determine the true anomaly

$$\frac{t}{T} \times 2\pi = M \Rightarrow M = 0.3 \times 2\pi$$

$$M \approx 1.88 \text{ rad}$$

$$M = E - e \sin E$$

$$M + e \sin E = E$$

Through iteration

$$E \approx 2.307 \text{ rad}$$

$$\cos E = \frac{e + \cos f}{1 + e \cos f}$$

$$f \approx 2.69 \text{ rad} \approx 153.88^\circ$$

Determine the distance

$$r(f) = \frac{a(1 - e^2)}{1 + e \cos f}$$

$$r = 2.21 \text{ AU}$$

Determine the velocity.

Because the object that is being considered is an asteroid, it is clear that it is orbiting the Sun.

$$v = \sqrt{2GM \left(\frac{1}{r} - \frac{1}{2a} \right)}$$

$$\boxed{v = 15.75 \text{ km/s}}$$

★ Solution of Day 41 ★

Check Problem Description: Day 41

Given:

- $T_{\text{moon}} = 29.53^d$ year,

$$\varepsilon = \frac{t_0}{T_{\text{moon}}} \times 360^\circ = 82^\circ 28' 19.42''$$

$$\phi = 180^\circ - \varepsilon = 97^\circ 31' 40.58''$$

Question: What is the phase?**Answer:** Determine the phase angle (ϕ) using elongation angle (ε)

Determine the phase percentage

$$t_{\text{full}} = \frac{T_{\text{moon}}}{2} = 14.77^d$$

$$t_0 = t_{\text{full}} - 8^d = 6.77^d$$

$$f\% = \left(\frac{1 + \cos \phi}{2} \right) \times 100\%$$

$$\boxed{f\% = 43.45\%}$$

★ Solution of Day 42 ★

Check Problem Description: Day 42

a) Energy Density of Radiation

$$\begin{aligned}\varepsilon &= \frac{4\sigma}{c} T^4 \\ \varepsilon_c &= \frac{3H^2 c^2}{8\pi G} \\ \Omega &= \frac{\varepsilon}{\varepsilon_c} \\ &= \frac{4\sigma T^4}{c} \frac{8\pi G}{3H^2 c^2} \\ \Omega &= \frac{32\pi G\sigma T_0^4}{3c^3 H_0^2} = 1\end{aligned}$$

- Flat ($\kappa = 0, \Omega_0 = 1$)

$$\begin{aligned}\Omega &= \frac{32\pi G\sigma T_0^4}{3c^3 H_0^2} > 1 \\ H_0 &> \left(\frac{32\pi G\sigma T_0^4}{3c^3} \right)^{\frac{1}{2}}\end{aligned}$$

- Positive Curvature ($\kappa = 1, \Omega_0 > 1$)

$$\begin{aligned}\Omega &= \frac{32\pi G\sigma T_0^4}{3c^3 H_0^2} = 1 \\ H_0 &= \left(\frac{32\pi G\sigma T_0^4}{3c^3} \right)^{\frac{1}{2}}\end{aligned}$$

- Negative Curvature ($\kappa = -1, \Omega_0 < 1$)

$$\begin{aligned}\Omega &= \frac{32\pi G\sigma T_0^4}{3c^3 H_0^2} < 1 \\ H_0 &< \left(\frac{32\pi G\sigma T_0^4}{3c^3} \right)^{\frac{1}{2}}\end{aligned}$$

b)

$$\begin{aligned}H^2 &= \frac{8\pi G}{3c^2} \varepsilon - \frac{\kappa c^2}{a^2 R_0^2} \\ R_0 &= \sqrt{\frac{\kappa c^2 a^{-2}}{\frac{8\pi G}{3c^2} \varepsilon - H^2}} \\ R_0 &= \sqrt{\frac{\kappa c^2}{\frac{32\pi G\sigma}{3c^3} T_0^4 - H_0^2}}\end{aligned}$$

c)

$$\begin{aligned}H_0^2 &= \frac{8\pi G}{3c^2} \varepsilon_0 - \frac{\kappa c^2}{R_0^2} \\ \frac{H^2}{H_0^2} &= \Omega_0 a^{-4} + \Omega_{\kappa,0} a^{-2} \\ \frac{da}{dt} &= H_0 \sqrt{\Omega_0 a^{-2} + \Omega_{\kappa,0}} \\ \int_0^a \frac{da}{\sqrt{\Omega_0 a^{-2} + \Omega_{\kappa,0}}} &= \int_0^t H_0 dt \\ \int \frac{a da}{\sqrt{\Omega_0 + \Omega_{\kappa,0} a^2}} &= H_0 t \\ u &= \Omega_0 + \Omega_{\kappa,0} a^2 \\ du &= 2\Omega_{\kappa,0} a da \\ \int \frac{\frac{1}{2} du}{\sqrt{u}} &= H_0 t \\ \frac{u^{\frac{1}{2}}}{\Omega_{\kappa,0}} &= H_0 t \\ \frac{\sqrt{\Omega_0 + \Omega_{\kappa,0} a^2} - \sqrt{\Omega_0}}{1 - \Omega_{\kappa,0}} &= H_0 t \\ \frac{\sqrt{\Omega_0 + (1 - \Omega_0) a^2} - \sqrt{\Omega_0}}{1 - \Omega_0} &= H_0 t \\ t_0 &= \frac{1 - \sqrt{\Omega_0}}{(1 - \Omega_0) H_0}\end{aligned}$$

d)

$$\begin{aligned}\Omega_0 &= \frac{32\pi G\sigma T_0^4}{9c^3 H_0^2} = 1.7 \times 10^{-5} \\ R_0 &= \sqrt{\frac{\kappa c^2}{\frac{32\pi G\sigma}{9c^3} T_0^4 - H_0^2}} = 4.29 \text{ Gpc} \\ t_0 &= \frac{1 - \sqrt{\Omega_0}}{(1 - \Omega_0) H_0} = 13.9 \text{ Gyr} \\ \frac{\sqrt{\Omega_0 + (1 - \Omega_0) a^2} - \sqrt{\Omega_0}}{1 - \Omega_0} &= H_0 t \\ a &= 0.502 \\ T &= T_0 a^{-1} \\ T &= 5.44 \text{ K}\end{aligned}$$

★ Solution of Day 43 ★

Check Problem Description: Day 43

Given:

1. $T_0 = T_{\text{spice}}$
2. $T' = T_{\text{eat}}$
3. $d = d$
4. $D = D$
5. $\rho = \rho_{\text{chicken}}$
6. $C = C_{\text{chicken}}$
7. $e = 0$

Question: How much time is needed to cook the chicken?**Answer:** Determine the duration

$$Q = m C \Delta T$$

$$E_{\odot} \cdot A \cdot \Delta t = m C \Delta T$$

$$\left[\frac{L_{\odot}}{4\pi d^2} \right] \cdot [l \times D] \cdot \Delta t = \left[\left(l \times \pi \left(\frac{1}{2} D \right)^2 \right) \times \rho_{\text{chicken}} \right] \cdot C_{\text{chicken}} \cdot [T_{\text{space}} - T_{\text{eat}}]$$

$$\left[\frac{L_{\odot}}{4\pi d^2} \right] \cdot [l \times D] \cdot \Delta t = \frac{\pi}{4} l D^2 \rho_{\text{chicken}} C_{\text{chicken}} \cdot [T_{\text{space}} - T_{\text{eat}}]$$

$$\Delta t = \frac{\pi^2 d^2 D \rho_{\text{chicken}} C_{\text{chicken}}}{L_{\odot}} \cdot [T_{\text{space}} - T_{\text{eat}}]$$

★ Solution of Day 44 ★

Check Problem Description: Day 44

Question: What is the Δt ?**Answer:** Because the Universe is flat

$$\rho = \rho_c$$

and because the Universe is matter-dominated

$$\rho = \rho_m$$

Therefore we can solve the problem by doing the following,

$$\rho_c = \frac{3H^2}{8\pi G}$$

$$\frac{\rho_{m,0}}{a^3} = \frac{3H^2}{8\pi G}$$

$$\frac{\rho_{c,0}}{a^3} = \frac{3H^2}{8\pi G}$$

$$\frac{1}{a^3} \frac{3H_0^2}{8\pi G} = \frac{3H^2}{8\pi G}$$

$$H = H_0 \cdot a^{-\frac{3}{2}}$$

$$\frac{1}{a} \cdot \frac{da}{dt} = H_0 \cdot a^{-\frac{3}{2}}$$

$$a^{\frac{1}{2}} da = H_0 dt$$

$$\int_0^{a'} a^{\frac{1}{2}} da = H_0 \int_{t_0}^{t'} dt$$

$$\frac{2}{a} \left(a^{\frac{3}{2}} \Big|_1^{a'} \right) = H_0 \cdot (t' - t_0)$$

$$\frac{2}{a} \left[(a')^{\frac{3}{2}} - 1 \right] = H_0 \cdot \Delta t$$

$$\Delta t = \frac{2a'^{\frac{3}{2}} - 1}{3H_0}$$

$$\Delta t = \frac{2\left(\frac{1}{100}\right)^{\frac{3}{2}} - 1}{3 \cdot (67 \text{ km/s/Mpc})}$$

$$\Delta t = 48.39 \times 10^6 \text{ years}$$

Since $T \propto a^{-1}$, that means we can get a' by doing the following:

$$\frac{T_0}{T'} = \frac{a'}{a}$$

Since $T_0 = 2.73 \text{ K}$ and $T' = 273 \text{ K}$, therefore

$$a' = \frac{1}{100}$$

★ Solution of Day 45 ★

Check Problem Description: Day 45

Given:

1. $\alpha = 30^\circ$,
2. $\delta = +20^\circ$,
3. $\Delta\lambda = +2.85 \text{ \AA}$,
4. $\mu_\alpha = 0.1''/\text{year}$,
5. $\theta = 63^\circ 1' 47.02''$,
6. $p = 0.02''$.

Question: What is the star's true velocity?**Answer:**

- Solving for tangential velocity

$$V_t = 4.74\mu d$$

$$\tan \theta = \frac{\mu_\delta}{\mu_\alpha \cos \delta} \implies \mu_\delta = \mu_\alpha \cos \delta \tan \theta$$

$$\mu_\delta = 0.185''/\text{year}$$

$$\mu = \sqrt{(\mu_\alpha \cos \delta)^2 + \mu_\delta^2} \implies \mu = 0.21''/\text{year}$$

$$p = 0.02'' \implies d = \frac{1}{p} = 50 \text{ pc}$$

$$\therefore V_t = 50 \text{ km/s}$$

- Solving for radial velocity

$$V_r = \frac{\lambda - \lambda_0}{\lambda_0} c$$

$$\Delta\lambda = \lambda - \lambda_0$$

$$\lambda_0 = 6564.67 \text{ \AA}$$

$$V_r = \frac{\Delta\lambda}{\lambda_0} c$$

$$\therefore V_r = 130 \text{ km/s}$$

- Solving for true velocity

$$V = \sqrt{V_t^2 + V_r^2}$$

$$V = 139.28 \text{ km/s}$$

★ Solution of Day 46 ★

Check Problem Description: Day 46

Given:

1. $\phi = 30^\circ$,
2. $a_0 = 0^\circ$,
3. $Az_0 = 50^\circ$,
4. $HA_\star = 3^h 5^m$.

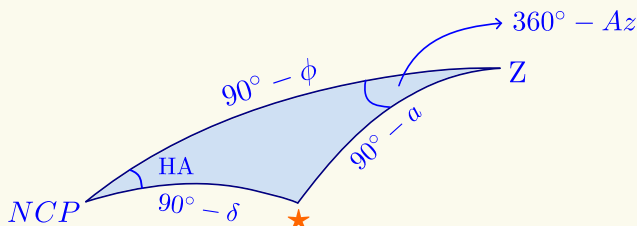
Question: What is the altitude and azimuth when $HA_\star = 3^h 5^m$?**Answer:**

- Determine the declination (δ_\star) of the star.

$$\sin \delta_\star = \sin \phi \sin a_0 + \cos \phi \cos a_0 \cos(360^\circ - Az)$$

$$\sin \delta_\star = \cos \phi \cos(310^\circ)$$

$$\delta_\star = 33^\circ 49' 33.04''$$

- Determine the altitude (a') of the star.

$$\sin a' = \sin \phi \sin \delta_\star + \cos \phi \cos \delta_\star \cos HA_\star$$

$$a' = 48^\circ 49' 26.95''$$

- Determine the Azimuth (Az') of the Star.

$$\sin \delta_\star = \sin \phi \sin a' + \cos \phi \cos a' \cos(360^\circ - Az)$$

$$\cos(360^\circ - Az) = \frac{\sin \delta_\star - \sin \phi \sin a'}{\cos \phi \cos a'}$$

$$Az = 288^\circ 26' 14.01''$$

★ Solution of Day 47 ★

Check Problem Description: Day 47

The Roche limit is the minimum distance at which a celestial body, held together only by its own gravity, can approach another more massive body without being torn apart by tidal forces. In the context of the Earth and the Moon, we derive the Roche limit by balancing the tidal forces exerted by the Earth and the self-gravity of the Moon.

Given:

1. $R_{\oplus} = 6378$ km,
2. $R_{\text{moon}} = 1737$ km,
3. $M_{\oplus} = 5.97 \times 10^{24}$ kg,
4. $M_{\text{moon}} = 7.35 \times 10^{22}$ kg.

Question: What is the Roche Limit between the Earth and the Moon?**Answer:** The tidal force F_{tidal} and the self-gravity $F_{\text{self-gravity}}$ are given by:

$$F_{\text{tidal}} \approx \frac{2GM_{\oplus}mR}{d^3}, \quad F_{\text{self-gravity}} = \frac{GM_{\text{Moon}}m}{R^2}.$$

At the Roche limit, these forces are equal:

$$\frac{2GM_{\oplus}mR}{d^3} = \frac{GM_{\text{Moon}}m}{R^2}.$$

Canceling G and m :

$$\frac{2M_{\oplus}R}{d^3} = \frac{M_{\text{Moon}}}{R^2}.$$

Rearranging for d :

$$d^3 = \frac{2M_{\oplus}R^3}{M_{\text{Moon}}},$$

$$d_R = R_{\text{moon}} \sqrt[3]{\frac{2M_{\oplus}}{M_{\text{moon}}}}$$

$$d_R = (1737 \times 10^3 \text{ m}) \cdot \sqrt[3]{2 \cdot \frac{5.97 \times 10^{24} \text{ kg}}{7.35 \times 10^{22} \text{ kg}}}$$

$$d_R = 9.45 \times 10^6 \text{ m}$$

★ Solution of Day 48 ★

Check Problem Description: Day 48

Given:

1. $N = 1800$,
2. $z = 0.0023$,
3. $\Omega = 90 \text{ deg}^2$.

Question: What is the average distance of the Galaxies?**Answer:**

- Determine the distance of the cluster Assuming $H_0 = 70 \text{ km/s/Mpc}$,

$$v_r = H_0 \cdot d$$

$$z = \frac{H_0 \cdot d}{c}$$

$$d = \frac{cz}{H_0} = 3.048 \times 10^{24} \text{ m}$$

$$d = 98.5 \text{ Mpc}$$

- Determine the radius of the cluster

$$\Omega = \frac{\pi\delta^2}{4} \implies \delta = \sqrt{\frac{4\Omega}{\pi}}$$

$$\delta = 0.187 \text{ rad}$$

$$R_c = d \cdot \frac{\delta}{2} = 2.85 \times 10^{20} \text{ m}$$

- Determine the volume of the cluster

$$V_c = \frac{4}{3}\pi R_c^3$$

$$V_c = 9.67 \times 10^{70} \text{ m}^3$$

$$V_c = 3263.7 \text{ Mpc}^3$$

- Determine the number density of the galaxies in the cluster

$$n = \frac{N}{V} = 0.552 \text{ galaxies/Mpc}^3$$

- Determine the average distance between galaxies

1. [Approx] Using the Wigner-Seitz Radius (r_s)

$$r_s = \left(\frac{3}{4\pi n} \right)^{\frac{1}{3}}$$

$$r_s = 0.756 \text{ Mpc}$$

2. [Exact] Using mean distances

$$\langle r \rangle = r_s \cdot \Gamma \left(\frac{4}{3} \right)$$

$$\langle r \rangle = 0.675 \text{ Mpc}$$

★ Solution of Day 49 ★

Check Problem Description: Day 49

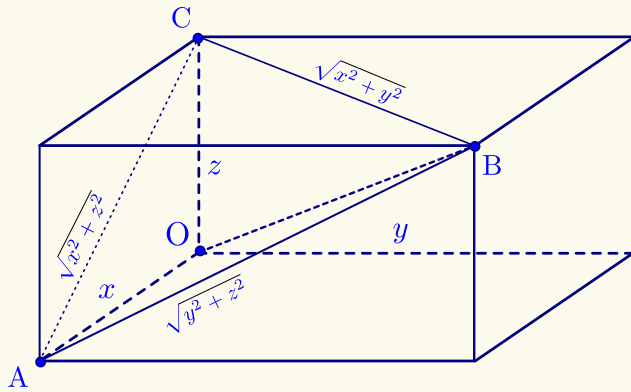

- $\cos \theta_{OC} = \frac{\sqrt{x^2 + y^2}}{\sqrt{x^2 + y^2 + z^2}}$
- $\sin \theta_{OC} = \frac{z}{\sqrt{x^2 + y^2 + z^2}}$
- $\cos \theta_{OA} = \frac{\sqrt{z^2 + y^2}}{\sqrt{x^2 + y^2 + z^2}}$
- $\sin \theta_{OA} = \frac{x}{\sqrt{x^2 + y^2 + z^2}}$

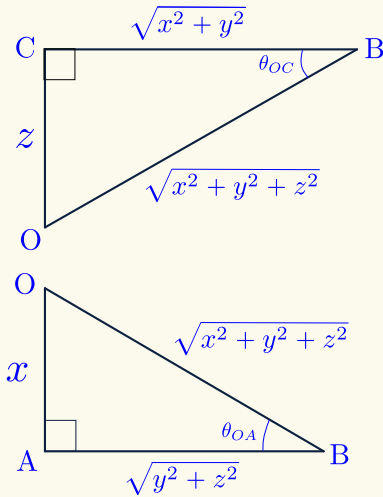

$$(AC)^2 = (BC)^2 + (AB)^2 - 2(AB)(BC) \cos \theta_{AC}$$

$$\cos \theta_{AC} = \frac{(x^2 + y^2) + (y^2 + z^2) - (x^2 + z^2)}{2\sqrt{x^2 + y^2}\sqrt{y^2 + z^2} - y^2}$$

$$= \frac{-y^2}{\sqrt{x^2 + y^2}\sqrt{y^2 + z^2}}$$

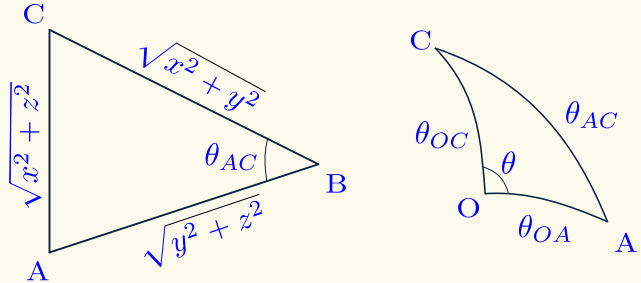

$$\cos \theta_{AC} = \cos \theta_{OC} \cos \theta_{OA} + \sin \theta_{OC} \sin \theta_{OA} \cos \theta$$

$$= \frac{y^2}{\sqrt{x^2 + y^2}\sqrt{y^2 + z^2}} - \frac{\sqrt{x^2 + y^2}\sqrt{y^2 + z^2}}{x^2 + y^2 + z^2}$$

$$= \frac{xz}{x^2 + y^2 + z^2}$$

$$= \frac{y^2(x^2 + y^2 + z^2) - (x^2 + y^2)(y^2 + z^2)}{xz\sqrt{x^2 + y^2}\sqrt{y^2 + z^2}}$$

$$\cos \theta = \frac{-xz}{\sqrt{x^2 + y^2}\sqrt{y^2 + z^2}}$$

★ Solution of Day 50 ★

Check Problem Description: Day 50

Given:

1. Purpose \implies The Sun,
2. Ambition \implies Capricorn,
3. Money \implies 2nd House,

Question: What is the time of birth?**Answer:**

- Determine the date the Sun has to be at Capricorn,

$$\lambda_{\odot} = \lambda_{cap} \approx 285^{\circ}$$

$$\lambda_{\odot} = \frac{n}{T} \times 360^{\circ}$$

$n \approx 15$ days after the Winter Solstice (Dec 22nd), So $n = 15^{\text{th}}$ Jan.

- Determine the time Capricorn must be at 2nd house, so the first house must be Aquarius ($\lambda_{Aqr} \approx 315^{\circ}$)

$$\lambda_{Aqr} \approx 315^{\circ}, \beta_{Aqr} = 0^{\circ}$$

$$\implies \alpha_{Aqr} = 21^h 10^m, \delta_{Aqr} = -16^{\circ} 23'$$

Aquarius Must be ascendant (rising)

$$\cos(HA_{rising}) = -\tan \phi \tan \delta_{Aqr}$$

$$HA_{rising} = -5^h 21^m$$

$$\tan \alpha_{\odot} = \cos \varepsilon \tan \delta_{\odot} \implies \alpha_{\odot} = 19^h 5^m$$

$$LST_{rise} = \alpha_{Aqr} + HA_{rise} = \alpha_{\odot} + HA_{\odot}$$

$$HA_{\odot} = -3^h 16^m$$

$$LT = HA_{\odot} + 12^h$$

$$LT = 8^h 44^m \implies 08.44 \text{ LT}$$

Therefore to obtain the desired perks of the New-born, the baby must be born on:

January 6th
08.44 LT at $\phi = 30^{\circ}$ N.

★ Solution of Day 51 ★

Check Problem Description: Day 51

- Shortest wavelength of the Balmer Series

$$\frac{1}{\lambda_{\min}} = \lim_{n \rightarrow \infty} R \left(\frac{1}{2^2} - \frac{1}{n^2} \right)$$

$$\frac{1}{\lambda_{\min}} = R \left(\frac{1}{2^2} - 0 \right)$$

$$\frac{1}{\lambda_{\min}} = \frac{R}{4}$$

$$\lambda_{\min} = 0.00003647039 \text{ cm}$$

$$\lambda_{\min} = 3647.04 \text{ \AA}$$

- Longest wavelength of the Balmer Series

$$\frac{1}{\lambda_{\max}} = R \left(\frac{1}{2^2} - \frac{1}{3^2} \right)$$

$$\lambda_{\max} = 0.00006564671 \text{ cm}$$

$$\lambda_{\max} = 6564.67 \text{ \AA}$$

Note. A great deal of effort went into analyzing the spectral data from the 1860s on. The big breakthrough was made by Johann Balmer, a math and Latin teacher at a girls' school in Basel, Switzerland. Balmer had done no physics before and made his great discovery when he was almost sixty. See this video: <https://youtu.be/XawP16g7dJ8?si=mcbsdpENi2j7B8Uv>

★ Solution of Day 52 ★

Check Problem Description: Day 52

Given:

1. $a_{\odot} = 0^{\circ}$,
2. $\phi = 35^{\circ}$ N,
3. Date: 17th July.

Answer:

- Determine the ecliptic longitude of the Sun (λ_{\odot}), below n is the amount of days after 21st of March.

$$\lambda_{\odot} = \frac{n}{365.25} \times 360^{\circ}$$

$$\lambda_{\odot} = \frac{118}{365.25} \times 360^{\circ} = 116.3^{\circ}$$

$$HA_{\odot, a_{\odot}=0}(\text{Sunset}) - HA_{\odot, a_{\odot}=0}(\text{Sunrise}) = \boxed{14^h 4^m 21.87^s}$$

- Determine the declination of the Sun (δ_{\odot}),

$$\sin \delta_{\odot} = \sin \varepsilon \sin \lambda_{\odot}$$

$$\delta_{\odot} = +20^{\circ} 56' 39.69''$$

- Determine the hour angle of the Sun at sunrise and sunset ($HA_{\odot, a_{\odot}=0}$)

$$\cos HA_{\odot, a_{\odot}=0} = -\tan \phi \tan \delta_{\odot}$$

$$HA_{\odot, a_{\odot}=0}(\text{Sunrise}) = 7^h 2^m 10.93^s$$

$$HA_{\odot, a_{\odot}=0}(\text{Sunset}) = -7^h 2^m 10.93^s$$

- Determine the duration of the day,

★ Solution of Day 53 ★

Check Problem Description: Day 53

Given:

1. $\Delta t = 8^h$,
2. $t = 22:56$ LT,
3. $f_0 = 0.23$,
4. Date: 4th of April.

Question: f' **Answer:**

- Determine the phase angle of the Moon (f_0).

$$f = \frac{1 + \cos \varphi}{2}$$

$$0.23 = \frac{1 + \cos \varphi}{2}$$

$$\varphi = 122^{\circ} 41' 1.1''$$

- Determine the change in phase angle (Δf),

$$\Delta f = \frac{\Delta t}{T_{\text{sin, moon}}} \times 360^{\circ}$$

$$\Delta f = 4^{\circ} 4' 4.07''$$

Note that there are two possible solutions for the phase. The phase right now f_0 could be representing the **waxing** crescent or the **waning** crescent.

- Determine the new phase (f')

$$f'_1 = \frac{1 + \cos(f_0 - \Delta f)}{2} = 0.2 \text{ (Waning)}$$

$$f'_2 = \frac{1 + \cos(f_0 + \Delta f)}{2} = 0.26 \text{ (Waxing)}$$

★ Solution of Day 54 ★

Check Problem Description: Day 54

Given:

$$1. \vec{v} = \begin{pmatrix} 50 \\ 24 \\ 2 \end{pmatrix} \text{ km/s}, \quad 2. \vec{r} = \begin{pmatrix} 10 \\ 2 \\ 14 \end{pmatrix} \text{ AU.}$$

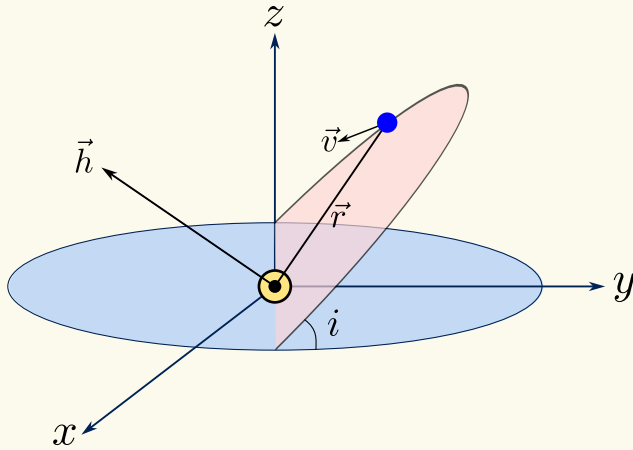
Answer:

Determine the vector of the North Ecliptic Pole. Note that you need to convert the km/s and AU in the SI unit first.

$$\vec{h} = \vec{r} \times \vec{v}$$

$$\vec{h} = \begin{pmatrix} -4.98 \times 10^{16} \\ 1.02 \times 10^{17} \\ 2.1 \times 10^{16} \end{pmatrix} \text{ m}^2/\text{s}$$

Determine the angle between the \vec{h} vector and z -axis unit vector \hat{k} (which is the inclination i)

$$\vec{h} \cdot \hat{k} = |\vec{h}| |\hat{k}| \cos \theta$$

$$\theta = \cos^{-1} \frac{\vec{h} \cdot \hat{k}}{|\vec{h}| |\hat{k}|} = \cos^{-1} \frac{2.1 \times 10^{16}}{1.15 \times 10^{17}}$$

$$\theta \equiv i = 79^\circ 31' 5.79''$$

★ Solution of Day 55 ★

Check Problem Description: Day 55

Given:

1. $D = 96 \text{ mm}$,
2. $m_s = 1.46$,
3. $t = 1 \text{ s}$.

Question: Determine the amount of photons.

Assumption:

1. $d_{pupil} = 8 \text{ mm}$,
2. $\lambda_{vis} = 500 \text{ nm}$,
3. Solar Constants.

Answer:

- Determine the flux received from Sirius in the visual band,

$$m_s - m_\odot = -2.5 \log \left(\frac{E_s}{E_\odot} \right)$$

$$E_s = 6.8 \times 10^{-9} \text{ Wm}^{-2}$$

- Determine the amount of energy that is received through the telescope

$$J = E_s \times \frac{\pi}{4} D^2 \times t$$

$$J = 4.92 \times 10^{-11} \text{ Joules}$$

- Determine the amount of photons

$$J = \frac{hc}{\lambda} \times N$$

$$N = \frac{J \times \lambda_v}{hc}$$

$$N = 1.24 \times 10^8 \text{ Joules}$$

★ Solution of Day 56 ★

Check Problem Description: Day 56

Given:

1. $z = 1.25$,
2. $m = 22.75$,
3. $\sigma_r = 220 \text{ km/s}$,
4. $\theta = 6.5'$,
5. $H_0 = 70 \text{ km/s/Mpc}$,
6. Flat, Matter dominated

a) From Friedman Equation

$$E(z) = \frac{H(z)}{H_0} = \sqrt{\Omega_{r,0}(1+z)^4 + \Omega_{m,0}(1+z)^3 + \Omega_{\kappa,0}(1+z)^2 + \Omega_{\Lambda}}$$

For flat and matter-dominated Universe

$$E(z) = \sqrt{\Omega_{m,0}(1+z)^3}$$

$$\Omega_{m,0} = 1$$

Proper distance (d_p)

$$d_p = \frac{c}{H_0} \int_0^z \frac{dz'}{E(z')}$$

$$= \frac{c}{H_0} \int_0^z (1+z')^{-\frac{3}{2}} dz'$$

$$= \frac{c}{H_0} \left(-2 \cdot \frac{1}{\sqrt{1+z'}} \right) \Big|_0^z$$

$$= \frac{2c}{H_0} \left(1 - \frac{1}{\sqrt{1+z}} \right)$$

$$d_p = 2.86 \text{ Gpc}$$

Angular diameter distance (d_A)

$$d_A = \frac{d_p}{1+z}$$

$$d_A = 1.27 \text{ Gpc}$$

Luminosity distance (d_L)

$$d_L = d_p(1+z)$$

$$d_L = 6.42 \text{ Gpc}$$

b) Absolute Magnitude (M)

$$m - M = -5 + 5 \log d_L$$

$$M = -21.29$$

Luminosity

$$M - M_{\odot} = -2.5 \log \left(\frac{L}{L_{\odot}} \right)$$

$$L = 2.73 \times 10^{10} L_{\odot}$$

c) Radius of the Galaxy

$$\theta = \frac{2R}{d_A}$$

$$R = \frac{1}{2} \theta d_A$$

$$R = 20 \text{ kpc}$$

From Virial Theorem

$$\langle U \rangle = -2 \langle K \rangle$$

$$\langle U \rangle = -2 \left\langle \frac{1}{2} M \langle v^2 \rangle \right\rangle$$

From uniform spherical mass distribution

$$U = -\frac{3}{5} \frac{GM^2}{R}$$

Assuming isotropic velocity distribution

$$\langle v^2 \rangle = 3 \langle v_r^2 \rangle = 3 \sigma_r^2$$

$$-\frac{3}{5} \frac{GM^2}{R} = -3M\sigma_r^2$$

$$M = \frac{5R\sigma_r^2}{G}$$

$$M = 1.12 \times 10^{12} M_{\odot}$$

d) Mass to Light ratio (M/L)

$$\frac{M}{L} = 41.08 M_{\odot}/L_{\odot}$$

★ Solution of Day 57 ★

Check Problem Description: Day 57

Given:

1. $M_{\odot} = 2 \times 10^{30} \text{ kg}$,
2. $R_{\odot} = 6.96 \times 10^8 \text{ m}$,
3. $L_{\odot} = 3.9 \times 10^{26} \text{ W}$.

Answer: Using the Kelvin-Helmholtz timescale

$$t_{KH} \approx \frac{0.5GM^2}{R} \frac{1}{L}$$

$$t_{KH} = 4.92 \times 10^{14} \text{ s}$$

$$t_{KH} = 15.58 \text{ Myr}$$

★ Solution of Day 58 ★

Check Problem Description: Day 58

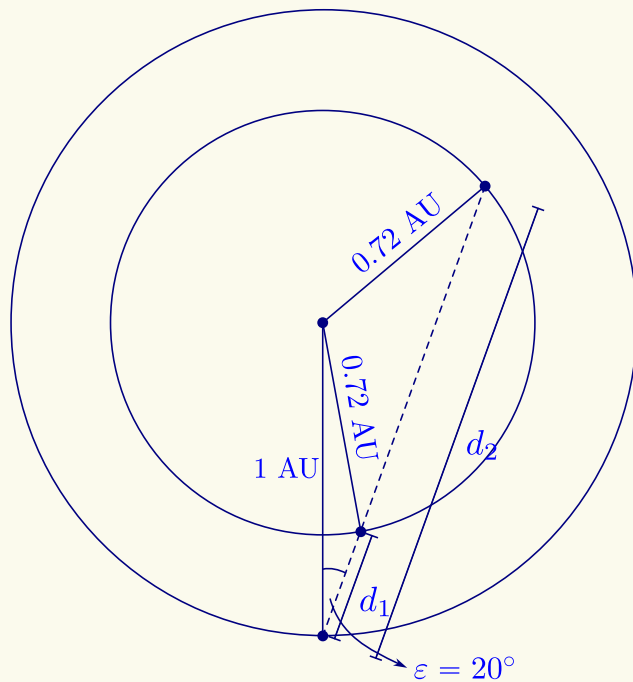
Solving for d using the Cosine rule

$$0.72^2 = 1^2 + d^2 - 2 \cdot 1 \cdot d \cdot \cos 20^\circ$$

$$0.72^2 - 1 = d^2 - (2 \cos 20^\circ)d$$

$$d^2 - (2 \cos 20^\circ)d + 0.482 = 0$$

Using the quadratic formula

$$d = \frac{2 \cos 20^\circ \pm \sqrt{(-2 \cos 20^\circ)^2 - 4 \times 1 \times 0.482}}{2 \times 1}$$

$$d = \frac{1.88 \pm \sqrt{1.61}}{2}$$

$$d_1 = 0.306 \text{ AU}, \quad d_2 = 1.57 \text{ AU}$$

★ Solution of Day 59 ★

Check Problem Description: Day 59

Given:

1. $f/D = 20$,
2. $f_{OB} = 1600 \text{ mm}$,

Question: What is the limiting magnitude?**Assumption:**

1. $d_{pupil} = 8 \text{ mm}$,
2. Limiting magnitude of the eye is 6.

Answer:

- Determine the aperture of the telescope

$$f/D = 20$$

$$D = \frac{1600}{20} \text{ mm}$$

$$D = 80 \text{ mm}$$

- Determine the light-gathering power (LGP)

$$LGP = \left(\frac{D}{d_{pupil}} \right)^2$$

$$LGP = \left(\frac{80}{8} \right)^2$$

$$LGP = 100$$

- Determine the limiting magnitude

$$m_{lim} = m_{lim,eye} + 2.5 \log(LGP)$$

$$m_{lim} = 6 + 2.5 \log(100)$$

$$m_{lim} = +11$$

★ Solution of Day 60 ★

Check Problem Description: Day 60

Given:

1. $f_0 = 110$ MHz,
2. $D = 10$ m,
3. Radio Band,
4. $t = 10$ s,
5. $f_1 = 108$ MHz,
6. $f_2 = 112$ Mhz.

Question:

1. Flux density of the Sun at 110 MHz (F),
2. # of photons received by a 10 m radio telescope at 108-112 MHz for 10s.

Assumption: Solar Constants.**Answer:**

- Determine the Flux density (F_ν) using Rayleigh-Jeans approximation

$$F_\nu = \pi B_\nu$$

$$F_\nu = \frac{2\pi\nu^2 kT}{c^2}$$

$$F_\nu = 6.77 \text{ MJy}$$

- Determine the emitted flux (F) of the Sun for the mentioned frequency band

$$F = F_\nu \cdot \Delta\nu$$

$$F = 6.77 \text{ MJy} \cdot [(112 - 108) \times 10^6]$$

$$F = 2.71 \times 10^{-13} \text{ Wm}^{-2} \text{ (On the Sun)}$$

- Determine the Luminosity and therefore the received flux

$$L = 4\pi R_\odot^2 F$$

$$L = 1.65 \times 10^6 \text{ W}$$

$$F = \frac{L}{4\pi d_\odot^2} = 5.83 \times 10^{-18} \text{ Wm}^{-2} \text{ (On the Sun)}$$

- Determine the total energy received

$$J = AEt$$

$$J = \frac{1}{4}\pi D^2 Et$$

$$J = \frac{1}{4}\pi \times 10^2 \times 5.83 \times 10^{-18} \times 10$$

$$J = 4.58 \times 10^{-15} \text{ Joules}$$

- Determine the photon count

$$E_{ph} = h\nu$$

$$E_{ph} = 7.29 \times 10^{-26} \text{ Joules}$$

$$N = \frac{J}{E_{ph}} = \boxed{6.29 \times 10^{10} \text{ photons}}$$

★ Solution of Day 61 ★

Check Problem Description: Day 61

Given:

1. $v_e = 0.6c$,

Question:

1. Kinetic Energy,
2. Momentum.

Assumption: Mass of the electron.**Answer:** Due to the velocity of the electron, the use of relativistic formulae is appropriate.

- Determine the Lorenz factor (γ)

$$\gamma = \frac{1}{\sqrt{1 - \frac{v^2}{c^2}}}$$

- Determine the kinetic energy

$$E_k = (1 - \gamma)m_e c^2$$

$$E_k = 0.25m_e c^2$$

$$E_k = 128 \text{ keV}$$

- Determine the momentum

$$p = \gamma m_e v$$

$$p = (1.25)m_e(0.6c)$$

$$p = 2.05 \times 10^{-22} \text{ Nm}$$

$$\boxed{p \approx 204 \text{ yNm}} \quad (\text{yoctonewton-metre})$$

★ Solution of Day 62 ★

Check Problem Description: Day 62

Given:

1. It has to be fully within the Goldilocks zone.
2. It is an asteroid

Question: Maximum Eccentricity **Assumption:** Goldilocks zone is defined where the water is liquid..

Answer:

- Determine the expression for the planet's distance as a function of distance

$$E_{input} = E_{output}$$

$$(1 - A) \pi R^2 E_{\odot} = 4\pi R^2 \sigma T^4$$

$$(1 - A) \pi R^2 \left(\frac{L_{\odot}}{4\pi d^2} \right) = 4\pi R^2 \sigma T^4$$

$$d = \sqrt{\frac{(1 - A)L_{\odot}}{16\pi\sigma T^4}}$$

- Determine the outer edge

$$d_{out} = \sqrt{\frac{(1 - A_{\oplus})L_{\odot}}{16\pi\sigma (273 \text{ K})^4}}$$

- Determine the inner edge

$$d_{in} = \sqrt{\frac{(1 - A_{\oplus})L_{\odot}}{16\pi\sigma (373 \text{ K})^4}}$$

Notice that r_{min} has to be d_{in} and r_{max} has to be d_{out} , therefore,

$$e = \frac{r_{max} - r_{min}}{r_{max} + r_{min}}$$

$$= \frac{\sqrt{\frac{(1 - A_{\oplus})L_{\odot}}{16\pi\sigma (273 \text{ K})^4}} - \sqrt{\frac{(1 - A_{\oplus})L_{\odot}}{16\pi\sigma (373 \text{ K})^4}}}{\sqrt{\frac{(1 - A_{\oplus})L_{\odot}}{16\pi\sigma (273 \text{ K})^4}} + \sqrt{\frac{(1 - A_{\oplus})L_{\odot}}{16\pi\sigma (373 \text{ K})^4}}}$$

$$= \frac{\sqrt{\frac{1}{273^4}} - \sqrt{\frac{1}{373^4}}}{\sqrt{\frac{1}{273^4}} + \sqrt{\frac{1}{373^4}}}$$

$$\boxed{e = 0.302}$$

★ Solution of Day 63 ★

Check Problem Description: Day 63

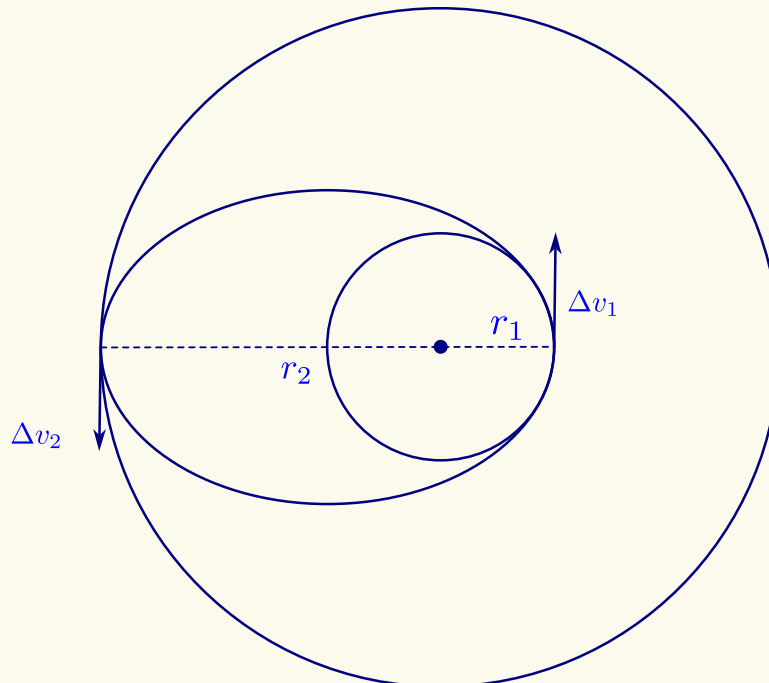

a. Semimajor of the Orbit

$$2a = r_1 + r_2$$

$$\Delta v_1 = v_{pe} - v_1$$

$$\Delta v_1 = \sqrt{2GM \left(\frac{1}{r_1} - \frac{1}{r_1 + r_2} \right)} - \sqrt{\frac{GM}{r_1}}$$

$$\Delta v_2 = \sqrt{2GM \left(\frac{1}{r_2} - \frac{1}{r_1 + r_2} \right)} - \sqrt{\frac{GM}{r_2}}$$

$$\Delta v = \Delta v_1 + \Delta v_2$$

$$\frac{\Delta v}{v_1} = \frac{\Delta v_1 + \Delta v_2}{v_1}$$

$$y = \sqrt{\frac{2r_2}{r_1 + r_2}} - 1 + \sqrt{\frac{r_1}{r_2}} - \sqrt{\frac{2r_1^2}{r_2(r_1 + r_2)}}$$

$$y = \sqrt{\frac{2 \cdot \frac{r_2}{r_1}}{1 + \frac{r_2}{r_1}}} - 1 + \sqrt{\frac{1}{\frac{r_2}{r_1}}} - \sqrt{\frac{2}{\frac{r_2}{r_1} \left(1 + \frac{r_2}{r_1} \right)}}$$

$$y = \sqrt{\frac{2x}{1+x}} + \sqrt{\frac{1}{x}} - \sqrt{\frac{2}{x(1+x)}} - 1$$

$$y = \frac{\sqrt{2GM \left(\frac{1}{r_1} - \frac{1}{r_1 + r_2} \right)} - \sqrt{\frac{GM}{r_1}} + \sqrt{2GM \left(\frac{1}{r_2} - \frac{1}{r_1 + r_2} \right)} - \sqrt{\frac{GM}{r_2}}}{\sqrt{\frac{GM}{r_1}}}$$

b. Take the differential of the function and set it to 0 to find the maximum

$$y = 2^{\frac{1}{2}} x^{\frac{1}{2}} (1+x)^{-\frac{1}{2}} + x^{-\frac{1}{2}} - 2^{\frac{1}{2}} x^{-\frac{1}{2}} (1+x)^{-\frac{1}{2}} - 1$$

$$\frac{dy}{dx} = 2^{\frac{1}{2}} \left[\frac{1}{2} x^{-\frac{1}{2}} \right] (1+x)^{-\frac{1}{2}} + 2^{\frac{1}{2}} x^{\frac{1}{2}} \left[-\frac{1}{2} (1+x)^{-\frac{3}{2}} \right] + \left[-\frac{1}{2} x^{-\frac{3}{2}} \right]$$

$$- 2^{\frac{1}{2}} \left[-\frac{1}{2} x^{-\frac{3}{2}} \right] (1+x)^{-\frac{1}{2}} - 2^{\frac{1}{2}} x^{-\frac{1}{2}} \left[-\frac{1}{2} (1+x)^{-\frac{3}{2}} \right] - 1$$

Simplify and set to 0

$$0 = x(1+x) - x^2 - 2^{-\frac{1}{2}}(1+x)^{\frac{3}{2}} + (1+x) + x$$

$$3x + 1 = 2^{-\frac{1}{2}}(1+x)^{\frac{3}{2}}$$

$$9x^2 + 6x + 1 = \frac{1}{2}(1 + 3x + 3x^2 + x^3)$$

$$x^3 - 15x^2 - 9x - 1 = 0$$

Solving for x and y

$$\begin{cases} x = 15.58 \\ y = 0.5363 \end{cases} \implies \begin{cases} \Delta v_{\max} = y \cdot v_1 = 16.01 \text{ km/s} \\ r_2 = x \cdot r_1 = 15.58 \text{ AU} \end{cases}$$

For Earth's orbit:

$$r_1 = 1 \text{ AU}$$

$$v_1 = \sqrt{\frac{GM}{r_1}} = 29.86 \text{ km/s}$$

c. Given:

1. $m_s = 200$ tons
2. $m_f = 500$ km/s
3. $v_e = 5$ km/s

Using ideal rocket equation,

$$\Delta v = v_e \cdot \ln \left(\frac{m_{initial}}{m_{final}} \right)$$

$$\Delta v = v_e \cdot \ln \left(\frac{m_s + m_f + m_p}{m_{final}} \right)$$

$$\Delta v = 16.29 \text{ km/s} \implies \Delta v > \Delta v_{\max}$$

This means all circular orbit larger than Earth's orbit is accessible.

For maximum payload (m_p), we can set $\Delta v = \Delta v_{\max}$

$$\Delta v = v_e \cdot \ln \left(\frac{m_{initial}}{m_{final}} \right) = \Delta v_{\max}$$

$$\Delta v_{\max} = v_e \cdot \ln \left(\frac{m_s + m_f + m_p}{m_{final}} \right)$$

$$\frac{m_s + m_f + m_p}{m_{final}} = e^{\frac{\Delta v_{\max}}{v_e}}$$

$$m_p = \frac{m_s + m_f - m_s \cdot e^{\frac{\Delta v_{\max}}{v_e}}}{e^{\frac{\Delta v_{\max}}{v_e}} - 1}$$

$$m_p = 1182 \text{ kg}$$

★ Solution of Day 64 ★

Check Problem Description: Day 64

Given: The time is April 15th, 14 UT

Question: What is the Julian date?

Answer: Calculate the Julian Date

$$JD = 365.25 \cdot (2024 + 4712) - 10 - 3 - 1 + (31 + 29 + 31 + 15) + \frac{2}{24}$$

$$JD = 2460416.083$$

Explanation:

1. 4712 comes from the reference year of the Julian date, which is 4713 BC
2. -10 comes from the Julian to Gregorian correction
3. The -3 comes from the reasoning that 3 years between 1582 and 2024 are multiples of 4 but not multiples of 400, which are 1700, 1800, and 1900.
4. The -1 comes from the year 2024 is a leap year.
5. $+(31 + 29 + 31 + 15)$ comes from counting the days until April 15th
6. $+\frac{2}{24}$ comes from the difference between the UT and the reference UT, which is 12 UT.

★ Solution of Day 65 ★

Check Problem Description: Day 65

Given: Current coordinates of the star Arcturus
 $((\alpha = 14^h 16^m, \delta = 19^\circ 5')$

Question: What are the new Equatorial coordinates?

Answer:

- Determine the change in ecliptic longitude $\Delta\lambda$,

$$\Delta\lambda = \frac{9000}{26000} \times 360^\circ$$

$$\Delta\lambda = 126^\circ 36' 55.38''$$

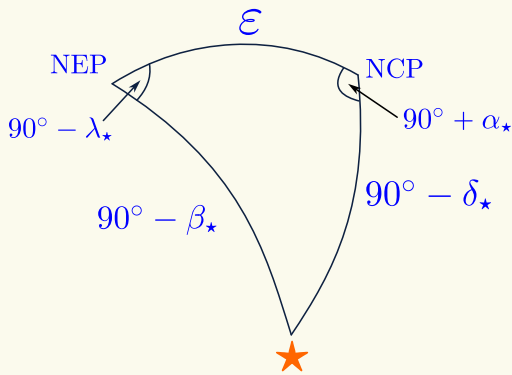

- Converting the current coordinate of Arcturus in Ecliptic coordinate

$$\sin \beta_* = \sin \delta_* \cos \varepsilon + \cos \delta_* \sin \varepsilon \cos(90^\circ + \alpha_*)$$

$$\beta_* = 30^\circ 42' 1.72''$$

Again,

$$\sin \delta_* = \sin \beta_* \cos \varepsilon + \cos \beta_* \sin \varepsilon \sin \lambda_*$$

$$\sin \lambda_* = \frac{\sin \delta_* - \sin \beta_* \cos \varepsilon}{\cos \beta_* \sin \varepsilon}$$

$$\lambda_* = -24^\circ 19' 51.43''$$

$$\Rightarrow 204^\circ 19' 51.43''$$

Using sine law,

$$\frac{\cos \lambda_*}{\cos \delta_*} = \frac{\cos \alpha_*}{\cos \beta_*}$$

$$\Rightarrow \lambda_* = 155^\circ 40' 8.57''$$

$$\lambda_* = 204^\circ 19' 51.43''$$

- Determine the ecliptic coordinate of Arcturus after precession

$$\beta'_* = \beta_*$$

$$\lambda'_* = \lambda_* + \Delta\lambda$$

- Determine the Equatorial coordinates after the precession

$$\sin \delta'_* = \sin \beta'_* \cos \varepsilon + \cos \beta'_* \sin \varepsilon \sin \lambda'_*$$

$$\delta'_* = 16^\circ 58' 37.38''$$

$$\sin \beta'_* = \sin \delta'_* \cos \varepsilon + \cos \delta'_* \sin \varepsilon \cos(90^\circ + \alpha'_*)$$

$$\sin \beta'_* = \sin \delta'_* \cos \varepsilon - \cos \delta'_* \sin \varepsilon \sin \alpha'_*$$

$$\sin \alpha'_* = \frac{\sin \beta'_* - \sin \delta'_* \cos \varepsilon}{-\cos \delta'_* \sin \varepsilon}$$

$$\Rightarrow \alpha'_* = -39^\circ 32' 17.67''$$

Again using sine law,

$$\frac{\cos \alpha'_*}{\cos \beta'_*} = \frac{\cos \lambda'_*}{\cos \delta'_*}$$

$$\alpha'_* = 39^\circ 37' 42.33''$$

$$\approx 320^\circ 22' 12.73''$$

$$\alpha'_* = 21^h 21^m 28.85^s$$

Note. Because of precession, our framework of Right Ascension and declination is constantly changing. Consequently, it is necessary to state the equator and equinox of the coordinate system to which any position is referred. Certain dates (e.g. 1950.0, 2000.0) are taken as standard epochs, and used for star catalogues, etc.

★ Solution of Day 66 ★

Check Problem Description: Day 66

Answer: Calculate the Julian Date

- Determine the $M(r)$ function

$$\rho = \frac{M}{V} \implies M(r) = \rho V$$

$$M(r) = \frac{4}{3}\pi r^3 \cdot \rho$$

- Determine the value of ρ

$$\rho = \frac{M}{\frac{4}{3}\pi R_{\odot}^3} = 1416.16 \text{ kg/m}^3$$

Solve the differential Hydrostatic equilibrium equation

$$\frac{dP}{dr} = -\frac{GM(r)}{r^2} \rho$$

$$dP = -G\rho \cdot \frac{M(r)}{r^2} dr$$

$$\int_{P_c}^0 dP = -G\rho \int_0^{R_{\odot}} \frac{M(r)}{r^2} dr$$

$$(P)_{P_c}^0 = -\frac{4}{3}\pi G\rho^2 \int_0^{R_{\odot}} r dr$$

$$-P_c = -\frac{4}{6}\pi G\rho^2 (r^2)_0^{R_{\odot}}$$

$$-P_c = -\frac{2}{3}\pi G\rho^2 R_{\odot}^2$$

$$P_c = \frac{2}{3}\pi G\rho^2 R_{\odot}^2$$

$$P_c = 1.36 \times 10^{14} \text{ Pa}$$

★ Solution of Day 67 ★

Check Problem Description: Day 67

Answer: Using Vectors

$$\vec{OA} = \begin{pmatrix} 30 \\ 23 \\ 12 \end{pmatrix} \text{ pc}, \quad \vec{OB} = \begin{pmatrix} 34 \\ 12 \\ 19 \end{pmatrix} \text{ pc}$$

$$\vec{AB} = \vec{OB} - \vec{OA}$$

$$\vec{AB} = \begin{pmatrix} 4 \\ -11 \\ 7 \end{pmatrix} \text{ pc}$$

$$|\vec{AB}| = \sqrt{4^2 + (-11)^2 + 7^2}$$

$$d_{AB} = 13.64 \text{ pc}$$

★ Solution of Day 68 ★

Check Problem Description: Day 68

Given:

1. $r = 2.97 \text{ AU}$.
2. $t = 7 \text{ year} = 2.21 \times 10^8 \text{ seconds}$
3. $t_0 = 1 \text{ hour} = 3600 \text{ seconds}$

Answer:

- Determine the Schwarzschild Radius of Gargantua

$$t = \frac{t_0}{\sqrt{1 - \frac{3r_s}{2r}}}$$

$$r_s = \left[1 - \left(\frac{t_0}{t} \right)^2 \right] \frac{2}{3} r$$

$$r_s = 1.98 \text{ AU}$$

- Determine the mass of Gargantua

$$r_s = \frac{2GM_G}{c^2}$$

$$M_G = \frac{r_s c^2}{2G}$$

$$M_G \approx 2 \times 10^{38} \text{ kg}$$

$$M_G \approx 100 \times 10^6 M_{\odot}$$

★ Solution of Day 69 ★

Check Problem Description: Day 69

Given:

$$T' = T_{\odot}$$

$$R' = \frac{1}{4}R_{\odot}$$

Answer:

$$\frac{L'}{L_{\odot}} = \frac{4\pi \left(\frac{1}{4}R_{\odot}\right)^2 \sigma T^4}{4\pi R_{\odot}^2 \sigma T^4}$$

$$\frac{L'}{L_{\odot}} = \frac{1}{16}$$

$$\frac{E'}{E_{\odot}} = \frac{\frac{L'}{4\pi d^2}}{\frac{L_{\odot}}{4\pi d^2}} = \frac{1}{16}$$

$$m' - m_{\odot} = -2.5 \log \left(\frac{E'}{E_{\odot}} \right)$$

$$\boxed{m' = -23.8}$$

★ Solution of Day 70 ★

Check Problem Description: Day 70

Given:

$$1. R = 4R_{\odot}.$$

$$L = 4\pi R^2 F$$

$$L = 8.58 \times 10^{24} \text{ W}$$

Using partial integration (Integral by parts), we get the emitted flux (F)

$$F = 8.82 \times 10^4 \text{ W/m}^2$$

c) Photon Count

$$p = 0.08'' \implies d = 12.5 \text{ pc}$$

Answer:

a) Temperature: $\lambda_{max} = 8000 \text{ \AA}$

$$b = \lambda_{max} \cdot T$$

$$T = \frac{b}{\lambda_{max}} = \frac{2.898 \times 10^{-3}}{8000 \times 10^{-10}}$$

$$T = 3622.5 \text{ K}$$

$$N_{photons} = \frac{L}{4\pi d^2} \cdot \left(\frac{1}{4}\pi D^2\right) \cdot \Delta t \cdot \eta \cdot \left(\frac{\lambda}{hc}\right)$$

$$N_{photons} = 7.89 \times 10^8 \text{ photons}$$

We know,

$$\text{Wien's Approximation} \implies \left(\frac{hc}{\lambda kT}\right) \gg 1$$

$$\lambda = 4000 \text{ \AA} \implies \frac{hc}{\lambda kT} = 9.95$$

d) Photon shot noise

$$\sigma = \sqrt{N_{photons}} = 28098 \text{ photons}$$

Signal-to-Noise ratio

$$\frac{S}{N} = \frac{N_{photons}}{\sigma} = 28098$$

b) Emitted Flux

$$\lambda_1 = \lambda - \frac{1}{2}\Delta\lambda = 3750 \text{ \AA}$$

$$\lambda_2 = \lambda + \frac{1}{2}\Delta\lambda = 4250 \text{ \AA}$$

e) Exposure time calculation

$$\frac{S}{N} = \frac{N_{photons}}{\sqrt{N_{photons}}} = \sqrt{N_{photons}}$$

$$N_{photons} \propto \Delta t \implies \frac{S}{N} \propto \sqrt{\Delta t}$$

$$\frac{S/N}{(S/N)_0} = 2 = \left(\frac{\Delta t}{\Delta t_0}\right)^{\frac{1}{2}}$$

$$F = \frac{2\pi hc^2}{\lambda^5} e^{-\frac{hc}{\lambda kT}} \quad (\text{Wien's Approximation})$$

$$F = \int_{\lambda_1}^{\lambda_2} F_{\lambda} d\lambda = \int_{\lambda_1}^{\lambda_2} \frac{2hc^2}{\lambda^5} e^{-\frac{hc}{\lambda kT}} d\lambda$$

Let $\frac{hc}{\lambda kT}$ be x and solve the following integral,

$$F = \frac{2\pi k^4 T^4}{h^3 c^2} \int_{x_1}^{x_2} -x^3 e^{-x} dx$$

$$\Delta t = 2^2 \cdot \Delta t_0$$

$$\Delta t = 100 \text{ seconds}$$

★ Solution of Day 71 ★

Check Problem Description: Day 71

Given:

1. $v_{rms} = 160 \text{ km s}^{-1}$
2. $m = m_p$

Answer:

$$\frac{1}{2}mv^2 = \frac{3}{2}kT$$

$$T = \frac{m_p v_{rms}^2}{3k}$$

$$\boxed{T = 1.03 \text{ MK}}$$

★ Solution of Day 72 ★

Check Problem Description: Day 72

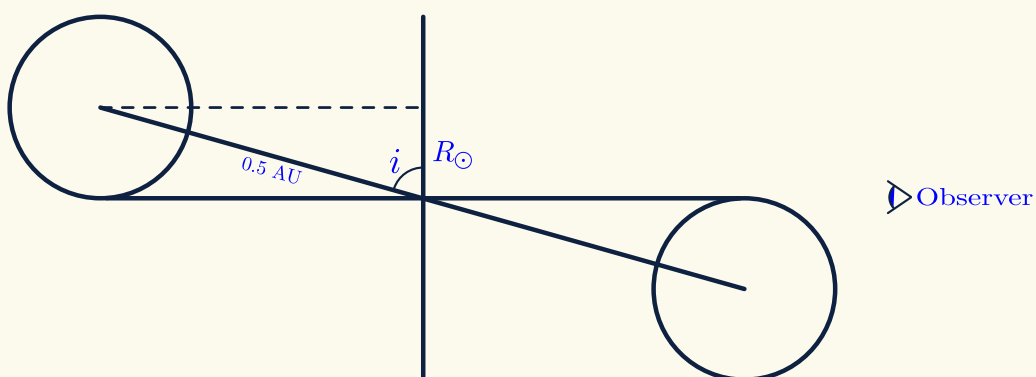

$$i = \cos^{-1} \left(\frac{R_{\odot}}{0.5 \text{ AU}} \right) = \cos^{-1} \left(\frac{6.96 \times 10^8}{0.5 \times 1.5 \times 10^{11}} \right)$$

$$\boxed{i = 89.47^\circ}$$

★ Solution of Day 73 ★

Check Problem Description: Day 73

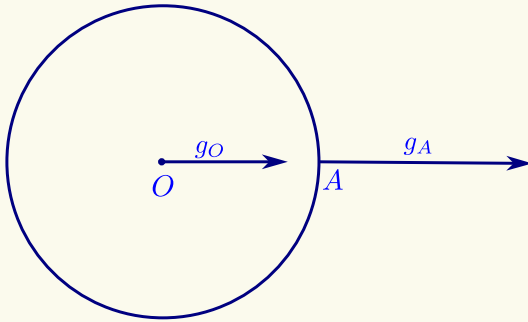

Relative to the Sun
(or the primary body)

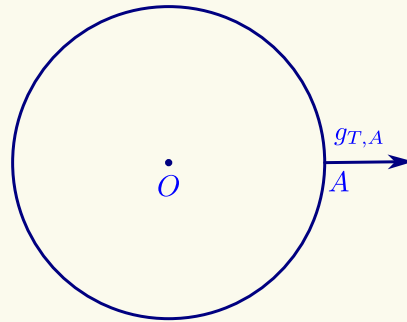

Relative to the center of Earth
(or the secondary body)

$$\begin{aligned}\vec{g}_{T,A} &= \vec{g}_A - \vec{g}_O \\ g_{T,A} &= g_A - g_O \\ g_{T,A} &= \frac{GM}{(d-R)^2} - \frac{GM}{R^2} \\ g_{T,A} &= -\frac{2GM}{d^3} R\end{aligned}$$

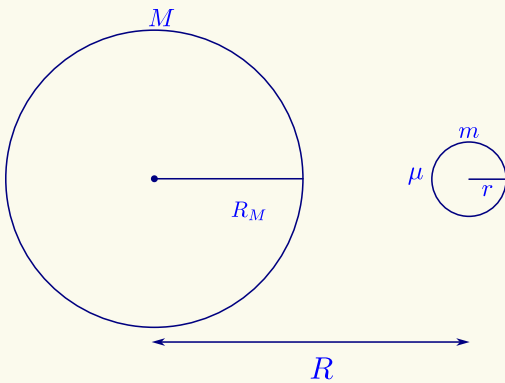

Therefore

$$\begin{aligned}F_T &= F_g \\ \frac{2G\mu M}{R^3} r &= \frac{G\mu m}{r^2} \\ \frac{2M}{R^3} &= \frac{m}{r^3} \\ \frac{2M}{R_M^3} R_M^3 &= \frac{m}{r^3} R^3 \\ 2\rho_M R_M^3 &= \rho_m R^3 \\ R_{roche} &= 2^{\frac{1}{3}} R_M \left(\frac{\rho_M}{\rho_m} \right)^{\frac{1}{3}} \\ R_{roche} &= 1.26 R_M \left(\frac{\rho_M}{\rho_m} \right)^{\frac{1}{3}}\end{aligned}$$

Therefore to determine the Roche limit of the Sun, to the Earth,

Using the model above, we can conclude that the Roche limit is the limit where the tidal forces between the primary and the test mass μ are exactly the gravitational force of the μ and m , or mathematically

$$F_T = F_g$$

Where, the tidal forces between the primary and the test mass

$$F_T = \frac{2GM\mu}{R^3} r$$

The gravitational forces between μ and m

$$F_g = \frac{GM\mu}{r^2}$$

$$\rho_{\odot} = \frac{M_{\odot}}{\frac{4}{3}\pi R_{\odot}^3} = 1416.16 \text{ kg/m}^3$$

$$\rho_{\oplus} = \frac{M_{\oplus}}{\frac{4}{3}\pi R_{\oplus}^3} = 5493.29 \text{ kg/m}^3$$

$$R_{roche} = 2^{\frac{1}{3}} (6.96 \times 10^8) \left(\frac{1416.16}{5493.29} \right)^{\frac{1}{3}}$$

$$R_{roche} = 2.26 \times 10^8 \text{ m}$$

$$R_{roche} \approx 0.00151 \text{ AU}$$

★ Solution of Day 74 ★

Check Problem Description: Day 74

$$L_0 = L'$$

$$m\sqrt{\mathcal{G}M_0R_0(1-e^2)} = m\sqrt{\mathcal{G}M'R'(1-e^2)}$$

$$M_0R_0 = M'R'$$

$$\frac{M_0}{M'} = \frac{R'}{R_0}$$

The $(1 - e^2)$ term cancels out because the orbit's eccentricity doesn't change over 100 years. Now due to thermonuclear reactions,

$$E = mc^2 \quad \frac{\Delta m}{\Delta t} = \frac{L}{c^2}$$

$$\frac{\Delta E}{\Delta t} = \frac{\Delta m}{\Delta t} c^2 \quad \frac{\Delta M_\odot}{\Delta t} = \frac{L_\odot}{c^2}$$

$$L = \frac{\Delta m}{\Delta t} c^2 \quad \frac{\Delta M_\odot}{\Delta t} = 4.34 \times 10^9 \text{ kg/s}$$

$$\Delta t = 100 \text{ years} \implies \Delta M_\odot = 1.37 \times 10^{19} \text{ kg}$$

$$M' = M_\odot - \Delta M_\odot$$

$$\frac{M'}{M_0} = \frac{M_\odot - \Delta M_\odot}{M_\odot} = \frac{R'}{R_0}$$

$$1 - \frac{\Delta M_\odot}{M_\odot} = \frac{R'}{R_0}$$

$$R' = \frac{R_0}{1 - \frac{\Delta M_\odot}{M_\odot}}$$

$$\therefore \boxed{\Delta R = 1.03 \text{ m}}$$

★ Solution of Day 75 ★

Check Problem Description: Day 75

For telescope magnification,

$$M = \frac{f_{OB}}{f_{OK}} = 90$$

$$\delta' = \delta_\odot \cdot M$$

$$\delta' = \frac{2 \times 6.96 \times 10^8}{1.5 \times 10^{11}} \cdot 90$$

$$\delta' = 0.835 \text{ rad}$$

$$\delta' = \frac{D_{plate}}{d_{plate}} = \frac{D_{plate}}{1.5}$$

$$\boxed{D_{plate} = 1.25 \text{ m}}$$

★ Solution of Day 76 ★

Check Problem Description: Day 76

Assume that the Earth has uniform density of ρ_\oplus .

$$\rho_\oplus = \frac{5.97 \times 10^{24}}{\frac{4}{3}\pi(6378000)^3} = 5493.29 \text{ kg/m}^3$$

- Determine the mass of the Earth from $R = 0$ to $R = R_\oplus - 10 \text{ km}$ (M_r)

Knowing the uniform density and the radius of the sphere, the mass of the sphere is:

$$M_r = \frac{4}{3}\pi(6368000)^3 \cdot \rho_\oplus = 5.94 \times 10^{24} \text{ kg}$$

- Determine the mass of the shell

$$M_{\text{shell}} = M_\oplus - M_r$$

$$M_{\text{shell}} = 2.8 \times 10^{22} \text{ kg}$$

- Determine the acceleration due to gravity using the Shell Theorem

$$g = \frac{GM_{\text{shell}}}{R_\oplus^2} = 0.046 \text{ m/s}^2$$

- Determine the weight of the person

$$W = m \cdot g = \boxed{3.22 \text{ N}}$$

★ Solution of Day 78 ★

Check Problem Description: Day 78

Given:

1. $M_{\text{total}} = 2 M_{\odot}$

2. $R = 5 \text{ AU.}$

$$v_{\text{total}} = \sqrt{\frac{GM_{\text{total}}}{R}} = 18.87 \text{ km/s}$$

$$v_1 = v_2 = \frac{1}{2} v_{\text{total}} = 9.43 \text{ km/s}$$

$$z = \frac{v}{c} = \frac{(\frac{1}{2} v_{\text{total}})}{c} = 0.0000315 \approx \boxed{3.15 \times 10^{-5}}$$

★ Solution of Day 79 ★

Check Problem Description: Day 79

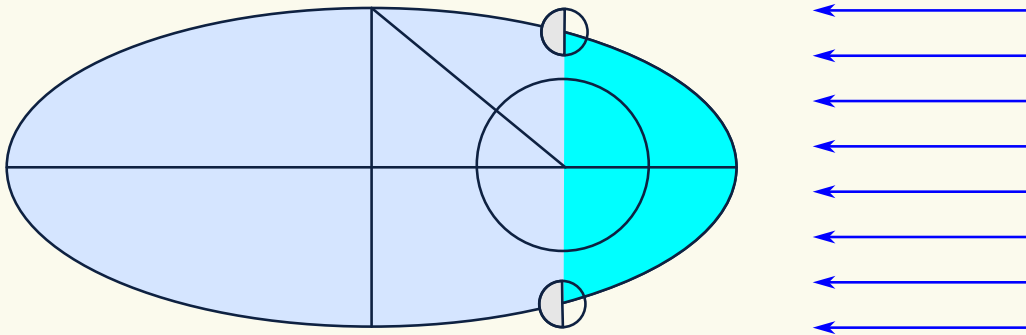

Assuming parallel rays and the Moon is at its perihelion on the new moon phase,

Given:

1. $e_{\text{moon}} = 0.0549,$

2. $a = 384,748 \text{ km.}$

3. The true anomaly ($f = 90^\circ$)

$M = 1.46$

$M = \frac{2\pi}{T} \cdot t$

$t = 6.39 \text{ days}$

The relation between Eccentric anomaly and true anomaly is given by

$$\cos E = \frac{e + \cos f}{1 + e \cos f}$$

$$E = 1.52$$

The Kepler's Equation

$$M = E - e \sin E$$

The ratio between the times,

$$t_1 = 2t = 12.79 \text{ days}$$

$$t_2 = T - t_1 = 14.71 \text{ days}$$

$$\therefore \frac{t_2}{t_1} = 1.15$$

★ Solution of Day 80 ★

Check Problem Description: Day 80

To figure out how many years between 2024 and 451227 are leap years, we'll consider the three following cases:

- Multiples of 4, between 2024 and 451227:

$$\frac{451224 - 2028}{4} + 1 = 112300$$

- Multiples of 100, between 2024 and 451227:

$$\frac{451200 - 2100}{100} + 1 = 4492$$

- Multiples of 400, between 2024 and 451227:

$$\frac{451200 - 2400}{400} + 1 = 1123$$

Then, by adding all the leap years; thereby knowing how many common years, we get that the number of days between the two May 31sts is **164068026**.

Days from 31st May until 21st October:

$$30 + 31 + 31 + 30 + 21 = 143$$

Therefore, $164068026 + 143 = 164068169$. which equates to 6 mod 7.

∴ 21 Oct 451227 is a **Thursday!**

★ Solution of Day 81 ★

Check Problem Description: Day 81

First, we begin by calculating the Luminosity of the B7 star:

$$\begin{aligned} L &= 4\pi(3.28R_{\odot})^2 \sigma(13000)^4 \\ &= 1.06 \times 10^{29} W \approx 271.94 L_{\odot} \end{aligned}$$

Then using Luminosity-Mass proportionality for Main sequence stars, we get the mass of the B7 star:

$$\begin{aligned} L &\propto M^{3.5} \\ \left(\frac{L}{L_{\odot}}\right) &= \left(\frac{M}{M_{\odot}}\right)^{3.5} \\ (271.94) &= M^{3.5} \end{aligned}$$

$$M \approx 4.96 M_{\odot}$$

Finally using Age-Luminosity proportionality for the main sequence stars, we get the age of the star cluster:

$$\begin{aligned} t &\propto M^{-2.5} \\ \left(\frac{t}{t_{\odot}}\right) &= \left(\frac{M}{M_{\odot}}\right)^{-2.5} \\ t &= (4.96)^{-2.5} \\ \boxed{t \approx 0.0182 t_{\odot}} \\ &\approx 182.43 \text{ Million years} \end{aligned}$$

★ Solution of Day 82 ★

Check Problem Description: Day 82

$$\begin{aligned} \frac{dr}{dt} &= -\frac{64 G^3 (m_1 m_2)(m_1 + m_2)}{5 c^5 r^3} \\ r^3 dr &= -\frac{64 G^3 (m_1 m_2)(m_1 + m_2)}{5 c^5} dt \\ \int_0^t dt &= -\frac{5 c^5}{64 G^3 (m_1 m_2)(m_1 + m_2)} \int_{r_0}^0 r^3 dr \\ t &= \frac{5 c^5 r_0^4}{256 G^3 (m_1 m_2)(m_1 + m_2)} \end{aligned}$$

Inserting $r_0 = 100 \text{ km}$ into the equation

$$\boxed{t = 0.362 \text{ seconds}}$$